

SAILING MANUAL

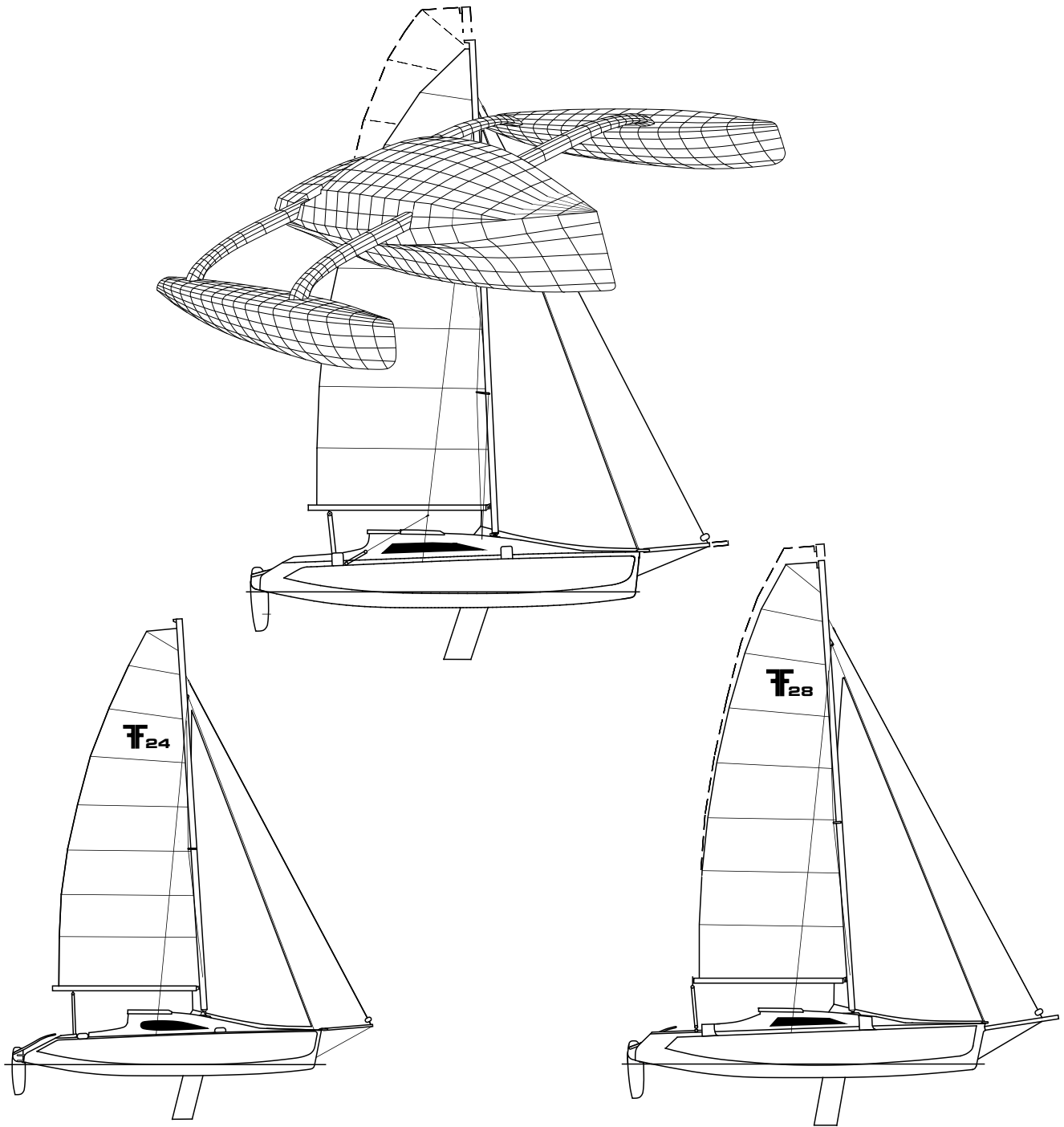

For All Corsair Models

Sailing Manual For All Corsair Models

Including F-24, F-28 and F-31

This manual has been compiled to help you to operate your craft with safety and enjoyment. It contains details of the craft, the equipment supplied or fitted, its systems, and information on its operation and maintenance. Please read it carefully and familiarize yourself with the craft before using it.

If this is your first craft, or you are changing to a type of craft you are not familiar with, for your own comfort or safety, please ensure that you obtain handling and operating experience before assuming command of the craft. Your dealer or national sailing federation or yacht club will be pleased to advise you of local sailing schools or competent instructors.

PLEASE KEEP THIS MANUAL IN A SECURE PLACE, AND PASS ON TO THE NEW OWNER WHEN YOU SELL THE CRAFT

Model _____ Hull Number _____

Owner 1. _____	Owner 2. _____	Owner 3. _____
_____	_____	_____
_____	_____	_____

Built By:

Corsair Marine, Inc.
150 Reed Court, Chula Vista, CA 91911, U.S.A.

Contents

General.....	3	Technical Notes.....	31
Preparation.....	3	Winch line.....	31
Loading	3	Spring Retaining Clips.....	31
Safety Compartment.....	4	Launching.....	31
Outboard Motor.....	4	Beam Bolts.....	31
Trailerling	5	Hoisting Mainsail.....	31
Rigging.....	6	Bearing Away.....	31
Launching.....	9	Heavy Helm.....	31
Mast Raising On The Water.....	11	Rudder/Daggerboard hum.....	31
Rudder.....	11	Rudder Ventilation.....	31
Daggerboard.....	11	Shroud Tensioners.....	32
Mast Setup.....	11	Compression Pads.....	32
Sailing.....	12	Wingnets.....	32
The Basics.....	12	Bimini Top Storage.....	32
Reefing.....	13	Float/Beam Vents.....	32
Rotating Mast Control.....	15	Rust.....	33
Windward Performance.....	15	Cleaning Floats.....	33
Reaching.....	16	Clean Boat Hint.....	33
Screacher.....	16	Collision.....	33
Spinnaker.....	17	Hurricane Survival.....	33
Spinnaker Jibing.....	17	SPECIFICATIONS	34
Spinnaker Sailing Downwind.....	18	F-24 Mk II Sail Plan.....	35
Safe Sailing Recommendations.....	19	F-28 & F-28R Sail Plan.....	36
Sailing Hints.....	21	F-31 Sail Plan.....	37
Anchoring.....	23	F-31R Sail Plan.....	38
Beaching.....	23	F-24 Interior.....	39
Retrieving To Trailer	23	F-24 Deck Layout.....	39
De-rigging	24	F-28 Interior.....	40
Lifting Out.....	26	F-28 Deck Layout.....	40
Marina Docking.....	26	F-31 Aft Cockpit Interior.....	41
Safety.....	26	F-31 Aft Cockpit Deck Layout.....	41
Unsinkability.....	27	Typical Trailer Setup	42
Offshore Sailing	27	Warranty & Limitation of Liability.....	43
Capsize.....	27	Maintenance & Safety Checklist	44
Righting.....	28		
Personal Responsibility	30		
Safety In General	31		



Corsair trimarans taking part in the 1997 U.S. National Titles, Pensacola, Florida. Farrier designs have now been sailing extensively world wide for over 20 years, and the experience from all these years is the basis for this manual.

GENERAL

This manual contains important information about the safe operation and maintenance of your Corsair built trimaran. Read it carefully, become familiar with the procedures described, and follow the recommendations to help make your sailing enjoyable and trouble-free.

Corsair trimarans are designed and built as high performance cruising yachts, which when used as intended, with their enormous stability and unsinkability, are among the safest and fastest yachts afloat.

As you become familiar with your boat, you may discover alternative methods of operation that have advantages. We would appreciate if you would share these with us so that we can share them with other owners.

PREPARATION

Before going sailing, you will need to provide the proper safety equipment as required by local regulations. This will usually include life jackets for all crew members, safety harnesses for children, anchor, compass, bilge pump, fog horn, First Aid kit, fire extinguishers, flashlight and batteries, life buoy, flares, a chart of the area to be sailed, food, water, and adequate fuel.

LOADING

Multihulls should be treated like **aircraft** when it comes to loading. Corsair trimarans are light, responsive craft, and due to their narrow waterline do not have an unlimited load carrying ability. Overloading can affect performance and handling, while excessive overloading can also affect safety margins, the ratio of float buoyancy relative to the total weight falling. A higher ratio is faster and safer. Always be conscious of weight and take care not to carry unnecessary items.

The load-carrying capacity of the different Corsair models is listed in the back of this manual. Some overloading is acceptable for general sailing in sheltered waters, the only adverse affect being a loss in performance. However, an overloaded boat offshore in large waves can become dangerous due to greater loads generated in the structure, and the sluggishness which can prevent the boat from rising to go over, or with the waves, as it should.

When storing supplies, try to keep all heavy items located as low down as possible and in the **forward end of the cabin**. Avoid storing any heavy items inside aft of the main entry hatch, as too much weight aft can cause transom drag, affecting performance. Farrier designs have a very buoyant bow, which actually **lifts** at speed, and additional weight

should always be kept forward rather than aft.

Should your model have float storage, avoid heavy loads in the floats. These should only be used for light bulky items such as sails, fenders etc. Heavy weight in the ends of any boat, be it the bow, stern, or floats, can adversely affect the general motion.

To maintain a light boat, and that sparkling edge to performance, it is highly recommended that you go through everything on board several times a year, and take off any items that do not get used. This prevents the gradual buildup of unnecessary weight.

SAFETY COMPARTMENT

Before sailing, it is important that the Safety Compartment be loaded with the appropriate safety gear. This compartment is accessible from top or bottom and is usually located in a cockpit coaming, or under the cockpit seat.

Its purpose is to keep important safety equipment that should be available to the crew in any emergency situation, including a capsized. The equipment stored here should include flares, a handheld VHF radio, EPIRB (offshore), extra line, spare tools, cutting implements etc. **in watertight bags** (this is not a watertight compartment).

No multihull should venture offshore without safety gear in such a compartment

OUTBOARD MOTOR

The recommended motor size is given in the specifications at the back of this manual and this is more than adequate for most circumstances.

A long shaft motor is the minimum required, and the **extra long 25" shaft motors are the best**. A remote control can also help make operation very easy with aft cabin models. With weight being important, try to choose a light outboard.

There are a number of specialist 'Sail Boat' motors now available and some of these are designed for heavy, hard to push, displacement boats, and their propellers are effectively 'geared down' to give high thrust at low speeds. However, Corsair trimarans have a very easily driven hull and may not need such a propeller. The result can be the same as always driving your car in low gear. You will have plenty of thrust, but speed is low, and economy can be poor. These motors do have advantages, and if used, you may need to experiment with different propellers to get the best and most efficient performance.

Refer to the engine manual for details of operation, maintenance and winter storage. Always be sure you have enough fuel for your planned trip.

The motor can be used while the floats are extended or folded and should always be tilted up when sailing.



The original prototype F-31 aft cabin, with outboard and underslung rudder system. This type of rudder can be removed altogether for long distance trailering. Aft cockpit models all now use transom hung rudders.



Light bar being fitted on an F-28. Note vertical position of transom hung rudder blade for trailering

The daggerboard **SHOULD ALWAYS BE DOWN** when motoring, to prevent any sideways movement. If not, the boat will have a hovercraft like motion with wide skidding turns. With the board down, handling is excellent.

TRAILERING

The total towing weight can vary considerably, depending on model and options, and can be determined exactly by using a weighbridge. Check that the vehicle is approved and equipped as recommended by its manufacturer for towing this weight, and the capacity of the towing hitch is suitable.

While towing, watch for strong crosswinds. A Corsair is a relatively light boat for towing, but it still has considerable windage. For easy, stable towing, the trailer should be balanced to have 5 to 10% of the total weight on the coupling ball. This can be measured by a bathroom scale. If you find 'fish tailing' occurs, increase this weight. If necessary, a simple change like shifting the gas tank or outboard forward can make a considerable difference to trailer behavior.

Trailer lights are fitted either on special brackets or as a separate light bar on the boat's transom. They are thus independent from the trailer, and the wiring never gets near the water, considerably improving reliability. If separate, be sure to fit the correct lights on the appropriate sides. The wire should be run along the top of the boat, looped around the

foredeck cleat and then connected to the towing vehicle. Independent wiring avoids the frequent breakdowns that occur with wiring through the trailer being attacked by saltwater. When the trailer is being towed on its own, the lights can be mounted directly to the trailer.

Before trailering, check that tires are inflated correctly, the beam locking pins are in place, the rudder is fully up and tied to one side, the pop-top or hatch is secured, and the boat is tied down to the trailer. There should be one tie-down per side, these being looped around the winches or brackets on the cockpit coamings, and tied to the tie-down loops on the trailer. The bow eye should also be tied down to the winch post, in addition to the winch line. Check that all the trailer supports always bear equally against the hulls.

When trailering, BE SURE to pivot up or remove the trailer jockey wheel, and that the hitch is locked on to the ball.

Should the mast extend back past the trailer lights by more than the legal amount, the appropriate warning flag should be tied on the back. The mast can be positioned far enough forward to eliminate any excessive overhang, but this may not be possible if the towing vehicle is a van.

When trailering, always allow extra distance for stopping. Particularly watch for **low bridges, overhanging trees or awnings** etc. If necessary, the boat can be partially unfolded on the trailer in order to pass under a low bridge.

CAUTION

*Measure and KNOW the overall height on the trailer.
Care should be taken to avoid all low, overhead
obstacles.*

RIGGING

The following is a general rigging procedure and applies to all models. There is also a separate more specific procedure for each model. For ease of rigging, it is highly recommended that you follow this general procedure, it having been developed from hundreds of launchings and proven to be fast, easy and efficient.

CAUTION

Always park into the wind, or uphill to help the mast stay in line while being winched up. Trailer should remain hooked to towing vehicle.

Two people should be able to completely rig an F-24, F-28 or F-31 ready to launch in under 20 minutes of arriving at the ramp by using the correct procedure. It is possible in fact, to be launched, unfolded, and sailing within 15 minutes with just two. One person should be able to have the boat rigged and launched in around 30 minutes. However, note that loading any extra gear or supplies onto the boat is not counted in these times.

DANGER

Before starting to rig, check to see that there are no powerlines for the mast to touch while being raised, or while being moved to the ramp.



Mast rolled back and being fitted to deck pivot brackets

Don't be dismayed if it takes you considerably longer the first few times out. It will take a little practice to become familiar with the procedures, and the more you rig the boat, the easier and quicker it will become. However, it is very important to follow a set procedure each time.

Recommended Set-Up Procedure Is As Follows:

1. Remove the trailer tie-downs, and the trailer lights. The tie-downs can be tied together and used as the bow line for launching. Saves stowing them, and then finding a bow line.

2. Undo the trailer winch hook, and pull some slack so that the hook will pass over the bow roller. Leave it lying on the foredeck.

3. Place the mast raising pole on the foredeck ready for use. Climb onto the bow using the nonskid areas on the float bows as stepping points.

CAUTION

The float bows can be slippery - particularly warn children to take care while climbing up or down.

4. Move aft alongside the mast undoing the mast ties (at each end) and the rigging ties as you go.

5. Lift the forward end of the mast and walk aft, rolling the mast on the aft mast roller while checking that the rigging wires do not catch. Stop once the mast foot is over the pivot brackets. Now's the time to fit any masthead indicator to the top of the mast. Lift the mast up until the indicator can be fitted to the masthead from the ground behind the boat. If rigging single-handed, the mast can usually be balanced in this position to enable fitting.

With F-28 & F-31R rotating masts, the mast yoke will now need to be fitted to the mast foot using the through pin (yoke can also be fitted prior to rolling mast back, or be left on the foot at prior de-rigging). Another alternative is to attach the yoke to the deck first, then fit the mast to it.

6. The mast foot is now connected to the mast step as follows:

F-24 Mk II: Plugged onto pin in the deck step.

F-28: Yoke is attached to the two deck brackets with fast pins

F-31: Plugged onto pin in deck step.

F-31R rotating: Attach yoke to deck brackets with fast pins



Mast raising pole in position on an F-28 with winch line connected to jib halyard, ready to raise mast. Shrouds must be attached to floats to prevent mast falling forwards.

With the F-31 non-rotating mast, it may be necessary to push the mast firmly aft to fit on the pin. If difficult, check that all stays are clear, the terminals into the mast have not snagged sideways, and the mast is centered on the aft roller.

7. Fit the mast raising wires . These are led from the eye around 8' up the front of the mast (side of the mast with non-rotating masts) to the side anchors on the cabin roof (aligned with the mast pivot point). These raising wire anchors can be 'clip on' or 'lift up loops' or extra chainplates, depending on model.

Note that the length of these raising wires is adjustable and they should be slightly loose and monitored on the first mast raising. This is to ensure they cannot become overtight during the initial raising procedure. They should never be more than moderately tight, and, once adjusted and set, should need no further monitoring or adjustment.

An alternative to raising wires is to use the spinnaker and screacher halyards. These can also provide an extra backup in difficult conditions, but they do take longer to setup. If used, they must be cleated at the bottom to the mast.

8. Position the mast raising pole on the mast or in the yoke socket. Attach the wire from the top of the pole to the eye on the front of the mast, with the pole being approximately perpendicular to the mast.

If considered necessary, (strong cross winds or single-handed) additional light side lines can be fitted from the pole end to the raising wire anchors to stabilize pole sideways.

Where the yoke is used (F-28 and F-31R rotating masts) the length of the wire from the pole to the mast can also be adjusted, and a little experimenting will give an almost perfect

moderate tension on the raising wires throughout the complete raising procedure.

9. Take the trailer winch line hook, pull it back over the pole and connect it to the jib halyard snapshackle (after it has been unhooked from the mast). Winch line should extend at least 2' aft of the mast pole fork.

Check to see that the jib halyard is **SECURELY TIED OFF** at the cleat on the side of the mast.

CAUTION

*With **rotating masts**, the shrouds must always be connected to the floats, otherwise there is a danger that mast could topple forward with over-winchng.*

10. The mast is now winched up, **CHECKING AGAIN FOR POWERLINES.**

Check to see that all rigging wires are clear and have not snagged anywhere, particularly aft chainplates on F-31s. Raising wires should initially be slightly loose, and tighten slightly on the way up.

WARNING

*During mast raising, it is very important to be alert to all items of rigging lifting or supporting the mast. If any resistance to raising is felt at any point, **STOP** and check that nothing has fouled. Do not proceed until any obstruction is clear*

If the mast raising pole tends to twist sideways this can be controlled by light lines to the raising wire anchors as mentioned earlier.



Mast on its way up and being held from going sideways by raising wires

Check that the socket in the rotating mast foot aligns correctly with the pivot ball on the deck, as the mast nears the fully up position.

CAUTION

Winch operator should be careful to ensure that the trailer winch line lays evenly across the drum while mast is being raised. With an offset bow roller, there can be a tendency for the incoming line to pile up on one side of the drum, to where it can suddenly slip off.

Monitor the float shrouds with rotating masts on initial rigging to ensure they do not become too tight or catch on anything during raising. F-28 and F-31R (rotating masts) have either special link plates or a Highfield lever system on the float decks that allow the shroud enough slack for the mast to be fully raised when the float is folded, while preventing any danger of the mast toppling forward. The F-24's special folding geometry allows this on its own.

These Link Plates are an important safeguard against accidentally dropping the mast while folding or unfolding, so do not remove.

The F-31 mast is large and heavy, with high loads, and extra caution should be taken to ensure it is not able to swing too far sideways. Never park in a cross wind or sideways on a slope, unless extra help is available to steady mast.

11. Once the mast is fully up, connect forestay. At initial rigging mast rake should be set to around 3 to 4°, which is 1

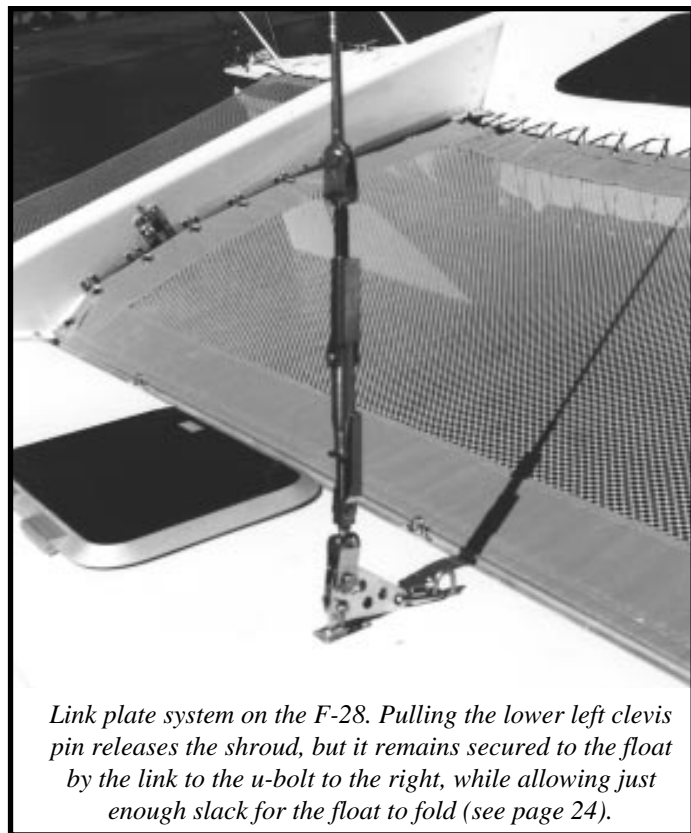

Link plate system on the F-28. Pulling the lower left clevis pin releases the shroud, but it remains secured to the float by the link to the u-bolt to the right, while allowing just enough slack for the float to fold (see page 24).

to 2° more than the rake of the aft edge of the forward beams when viewed from the side. Once initial adjustment has been done, the forestay turnbuckle **does not need to be undone during normal rigging or de-rigging**, only the clevis pin is removed or inserted.

Lower and intermediate shrouds on the fixed F-31 mast **remain connected during all rigging and de-rigging** procedures. After the initial adjustment, there is also **no need to undo** these or disconnect them from the shroud chainplates.



Always leave mast raising wires attached until after the boat is unfolded. F-28 'fold down' anchoring loops shown here.

12. Once forestay is connected, slacken off the trailer winch, disconnect the jib halyard, and return it to the mast. Remove raising pole, mast yoke, rewind the winch and reconnect hook to the bow eye.

Leave mast raising wires attached to the mast, as these are still required for support until after the floats are unfolded and shrouds properly connected to floats.

13. The topping lift is now disconnected from the mast lower end and connected to the end of the boom to help take the weight. Remove the sail bag from the mainsail/boom and connect the boom to the mast.

14. Tighten all the battens in the mainsail, if required. Connect the mainsheet to the boom. Feed the mainsail head into the track on the mast and connect the main halyard

15. Run all the halyard lines from the mast through the turning blocks back to the correct rope clutches on the aft end of the cabin roof.

16. Connect the mast electric plug if required.

17. The headsail can be fitted now if wished, or after launching. The sheets are laid out and connected to the clew (sheets can be kept in the anchor well for quick access). The headsail can be kept under control by a shockcord which can be left on the foredeck for this purpose. Just keep it hooked to the toerail or pulpit.

18. Untie the rudder, and check that the daggerboard up-line is cleated. The **outboard** motor should also be in the **up position**.

19. The aft mast support is now removed and stored. You are now ready to launch.

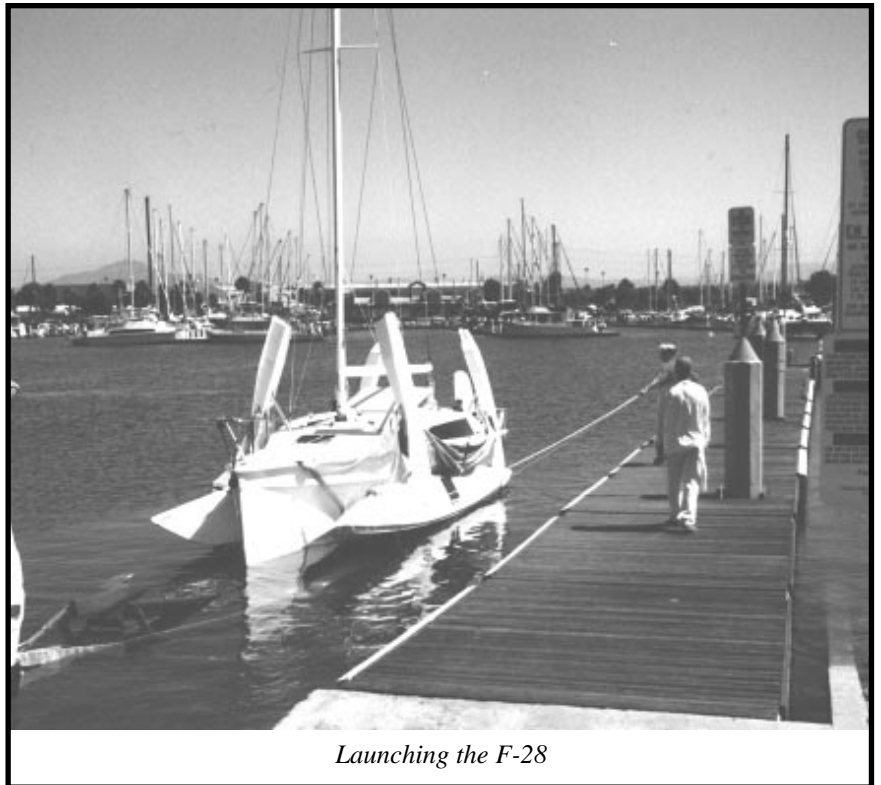

Launching the F-28

LAUNCHING

WARNING

Before taking the boat to the ramp, check to see that there are no powerlines for the mast to touch.

Back the trailer down the ramp until the trailer is submerged up until just past the inward bend of the side frame members (about 6 to 8' back from the winch post).

Disconnect the winch hook and push the boat off, while holding on to the bow line, or you can get on board (but start the motor first before pushing off). Be careful of crosswinds or wind from the stern. The boat, with its shallow draft, will move quickly sideways in such conditions, and you should not launch until there is sufficient maneuvering room alongside.

This ability to go sideways is one drawback of shallow draft, and you should always make allowances when launching/retrieving or under power. **First priority** at every launch should be to **LOWER THE DAGGERBOARD!** This helps to prevent any sideways movement, and gives excellent maneuverability under power.

The F-31 is a large boat to handle at ramps, but because of its lightness, it is easy to move around. The trick is not to fight it, but to plan ahead what you are going to do, and gently guide it in the correct direction.

An offshore wind at the ramp is ideal, as the boat will just lie quietly downwind at the end of the bow line. It is just then a simple matter of boarding over the float bows, and backing off or just walking her over to a boarding dock, if available.

An onshore wind is the most difficult, as the boat will swing

sideways once launched, and come towards the ramp. In this situation the boat should be held off the ramp from a central position on the side. You will find a balance point where it will lie evenly until you are ready to board.

If a dock is alongside it is a good idea to run a stern line to the dock, so that the stern can be pulled to the dock after launching, thus preventing it from swinging around.

A good way of launching in all conditions, if extra help is available, is for someone on board to start the motor before launching, and simply back the boat away from the ramp - remembering, of course, to drop the daggerboard once clear of the trailer.

All models are always launched folded, and unfolding can be done either at the dock, or while motoring away, even in choppy conditions. Folded stability is very good, **but it is limited, particularly on bigger boats like the F-28 and F-31.** Always take care in strong crosswinds and avoid fast tight turns, as it is possible to roll the boat over! If necessary, immediately unfold at least one side to avoid any risk. The F-31 also has a secondary wider folded beam of 9' 6" which improves folded stability, and if you intend motoring very far while folded, you should use this position.

WARNING

Always take care in strong winds while fully folded and with mast up. A combination of a fast tight turn and mast windage and weight could cause a roll over in such conditions. If in doubt, unfold one or both sides to eliminate this danger

To unfold, first check that there are no ropes across the



*Unfolding can be done at the dock or while motoring away.
But beware, while folding stability is good, it is limited.*

beam recesses, and the tiller is clear. Remove the beam locking pins, **place your foot on the top of the upper folding strut**, grasp the top of the beam and pull downwards, while pushing with your foot.

WARNING

Always check that no one has their foot/hand/fingers in or near the beam recesses when folding, as the beams can come down quickly!

The float will unfold, but be careful it doesn't pick up too much speed towards the end. Hold the beam down and tighten the bolts using a speed wrench. These bolts should be tightened firmly, but NOT OVERTIGHTENED.

WARNING

The Beam Bolts must always be in place and tightened BEFORE sailing

If anything seems hard or difficult when folding, STOP and see if anything is misaligned, or snagged. It is usually a wingnet catching. Should you have difficulty in holding the beams down to tighten the bolts, then the usual cause is wingnets that have been lashed too tightly. These should be slackened slightly.

It is not necessary to hold both forward and aft beams

when folding, one person operating either beam is all that is required. The wingnets will extend and tighten themselves. There is a knack in unfolding of using both your foot to push on the upper folding strut and your hands to pull the top of the beam in and down. After a few tries you will find it easy to do.

The shrouds are now secured correctly to the floats, with the Link Plate (if fitted) being pinned to the chainplate. The F-24 Mk II does not require this, as its shrouds can be left permanently attached to chainplate.

With the F-31 fixed mast, the turnbuckle must be directly connected to chainplate, and there should be just enough slack in the wire (**but not too much** - which can overload tensioners) to insert the clevis pins. The top shrouds are then tensioned by the block and tackle tensioners anchored at the aft beams and attached to the shackle located about 4' up the top shrouds. Pull these on firmly, checking that the mast is straight. The first time out, both tensioner lines should be marked when the mast is straight, as a reference for future use and adjustment.

These tensioner tackles on fixed masts will need considerable tightening when going to windward in high winds, as they keep the mast straight and forestay tight for good pointing ability. Avoid letting the leeward shroud become too loose.

Rotating mast shrouds only need to be moderately tight, even slightly loose, as a tight rig can restrict rotation.

Once adjusted at initial launching, all turnbuckles can remain fixed, and should not require to be adjusted during launching or retrieving. Just the spring clip and clevis pin are inserted or removed in the turnbuckle toggle or Link Plate.

Once the mast is properly supported by the shrouds, the mast raising wires can be removed.

The spinnaker pole bowsprit can now be fitted or extended depending on model.



Beam bolts must always be tightened firmly before sailing

MAST RAISING ON THE WATER

It may be necessary to sometimes launch with the mast down and raise the mast later. To do this **you will need an additional strong block** to attach to the bow roller/stem fitting. A spinnaker sheet block is ideal. The mast raising pole/yoke must also be carried on board.

Once in clear water, follow the same mast setup and raising procedures as listed under RIGGING, but instead of the trailer winch line, use a line from a sheet winch to the bow block, and then back to the jib halyard. The mast can then be winched up. The procedure is reversed for lowering.

RUDDER



F-28 transom hung rudder being lifted up - note how tiller can give extra leverage by pull up line being cleated to it.

The rudder has 2 control lines, one to pull up and one to pull down. These are color coded, with red (for danger) to pull up, blue, for deep water, to pull down. The rudder will kick back, should it hit bottom hard enough, the pull down line pulling through the cleat.

At high speeds, the cleat alone may not be enough to hold the rudder down. In this case, a lock/shear pin can be fitted through the case and blade as a positive lock down.

The rudder may also have an extra horn cleat on the tiller, and this should only be used if the hold down cleat is worn, and the lock/shear pin is not available. Never use the horn cleat where there is a danger of grounding.

DAGGERBOARD

Like the rudder, the daggerboard has 2 control lines, one to pull up (red) and one to pull down (blue). The daggerboard will not kick back, it being designed to break off should it ever hit bottom hard enough. This protects the daggerboard case from damage in most cases - a much more expensive repair. Obviously, one should still be careful around shallow waters,

keeping alert, and the boat speed down. The daggerboard is very strong and will only break off with an exceptionally hard grounding. Normally you can expect the boat to come to a shuddering stop, with no damage, should you hit bottom at speeds less than 6 knots or so. It's then just a matter of retracting the daggerboard and continuing on your way.

CAUTION

Even at low speeds, a grounding can cause the crew to be thrown forward, and care should be taken to prevent this, or to be prepared for it. Slow Down In Shallow Water.

The daggerboard case itself is exceptionally strong, and is not likely to be damaged in a grounding, though this cannot be guaranteed. Even with a lost daggerboard, your Corsair trimaran will still be sailable, and will still go to windward. In this case you should allow her to heel as far as possible, submerging the lee float to pick up lateral area.

When maneuvering in confined waters **always have the board down**. This promotes quick turns, preventing any sideways motion. In general, the board should always be down, except perhaps when running downwind in light conditions. However, no speed advantage has ever been proven for this, so it is probably easier to just leave it down.

The board should always be half to fully down when running or reaching in heavy winds or seas. It greatly enhances directional control, keeping the tiller very light.

Should you at any time find the helm heavy, then the cause is either, the daggerboard is up, or, the rudder has kicked back slightly (always watch for this). Another possible cause can be the mainsail sheeted in too tight (a common fault). Even in the strongest winds, or the fastest 20 knot spinnaker run, the helm should always be light enough for easy one-handed control. If not, you should check for reasons why.

MAST SETUP

Rig tension and mast setup are very important for good

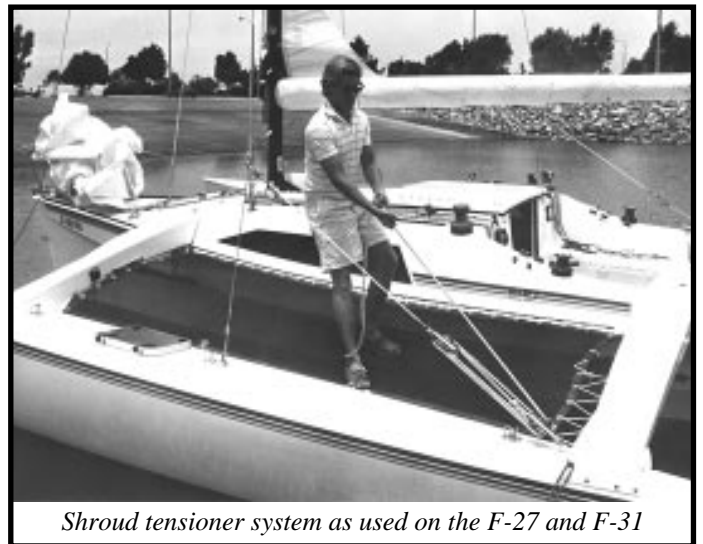

Shroud tensioner system as used on the F-27 and F-31

sailing performance and while rotating masts do not require much rig tension (to allow full mast rotation), most owners do not tension fixed mast rigs enough. To avoid this, a simple rig tension gauge (Loos Type recommended) available at Marine stores can be purchased, and this includes hints on tensioning your rig. Rigging wire will stretch a little initially and all settings should be checked after a few sails.

All masts should be set up with some prebend (center of mast pushed forward). This will range from as little as 3/4" with Rotating masts (even less with wing masts), to 3 to 5" with fixed masts. Mainsail should then be cut to suit this.

There is no correct amount of prebend, other than each mast should have some, and it can be used to control the mainsail shape to some degree. This means that if the mainsail is cut for say 3" prebend, less will make the main fuller for light airs. More, will tend to flatten the main for windy conditions.

Prebend in Rotating masts is harder to adjust in this regard, but the ability to rotate the mast can give an even greater control over mainsail fullness.

For good windward performance the forestay **MUST BE TIGHT** and this cannot be emphasized too much. Fixed masts can control this by pulling on the shroud tensioners, and more mainsheet tension. Rotating masts can only increase mainsheet tension, but the superior mainsail shape due to the rotating mast, more than makes up for this.

An important rule, vital to the well being of all masts, particularly fixed masts, is to be sure that your leeward cap shroud never becomes **TOO LOOSE**. Some looseness is not unusual, but if it is very loose and visibly flopping around, you could risk losing your mast.

To tighten the shrouds on a fixed mast while underway,

you can use the spinnaker winches on the tensioners, or else snug up the leeward tensioner a set amount to just remove any slack. Now tack and pull on the other side an equal amount. It is easier to tension the leeward shroud rather than the windward one. On the F-31 fixed mast the top shroud's tension in heavy weather should always be 2500lbs or more..... **Don't forget to relieve this when not sailing.**

SAILING

This manual is not intended to be a Sailing Instruction Manual, and it is presumed that all owners will have a basic sailing knowledge and skill. There are however, many aspects of sailing a Corsair trimaran efficiently, and the following covers some of these:

THE BASICS

The mainsail is usually hoisted first. Turn directly into the wind and commence pulling on the halyard. You may find winching necessary to get the main fully up, and if fitted, use the jib halyard winch. If the boom roller furling system is fitted, the main will automatically unroll from the boom. Winch the halyard tight until all the wrinkles just disappear from the mainsail luff, no tighter, and lock the halyard with the rope clutch. The topping lift can now be eased.

All models sail and tack easily under mainsail alone. If you have a lot of tacking to clear a channel then it may be much easier with just the main. You don't have to worry about tacking the jib, you won't be going too fast, particularly in crowded waters, and visibility is excellent.

The correct technique for sailing mainsail only is to sheet it free to avoid choking the boat. The traveller can be locked on the centerline, and the mainsheet slackened off so the

boom is about 12" out from center. Your boat speed should be 5 - 6 knots in 10 to 15 knots of wind, even better with a rotating mast. If you find boat speed is less, then the problem is an over-sheeted main or trying to point too high.

There is a technique involved in sailing main only, and once learned how, it is a very relaxed form of sailing. The secret is to keep the main eased out more, particularly after a tack. Don't try to point high until boatspeed has built up.

The jib halyard can now be connected and the jib hoisted. Tighten until the wrinkles just disappear from the jib luff, using the halyard winch if needed. There's no need to go any tighter. As the wind increases you will find the halyard will need tightening,

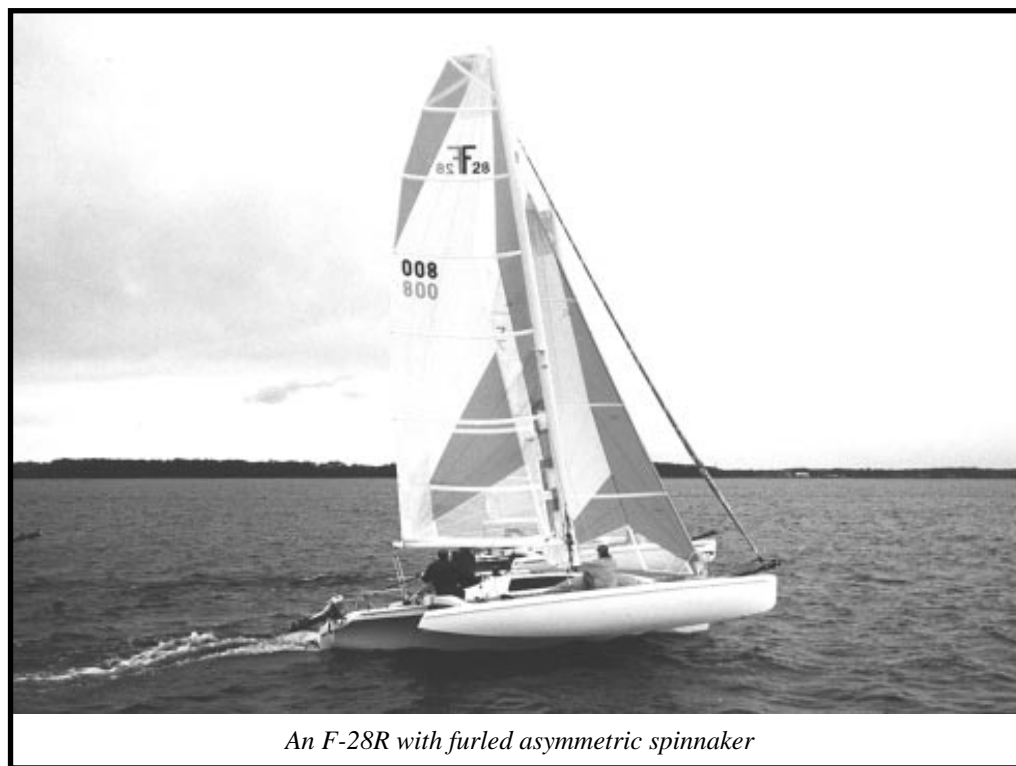

An F-28R with furled asymmetric spinnaker



Boom vang and Cunningham eye controls on an F-27

When reaching, the headsail shape can be improved by using a barber hauler. This is a line hooked to the headsail clew, and led to a block attached to an eye on the float deck and then back to a camcleat on the cockpit coaming. Two barber haulers give a wide range of sheet adjustment. One can also be used on the boom to hold it down while running or reaching. This is much more efficient than the traditional boom vang and a good safety feature to prevent an unexpected jibe.

For the best performance while running, weight should be kept forward. At least one crew member should sit on the main hull bow when racing downwind. This reduces wetted area and can make a significant difference.

again, just enough to just get the wrinkles out. Sheet the jib and you are sailing!

If available, two additional controls may be added to the mainsail at this stage, these being the boom vang (fixed masts only) which just snaps on, and the Cunningham eye tackle. A 4:1 fiddle block with cleat is snap shackled to the mast step, and the line from the top fiddle block is passed through the Cunningham eye on the sail and hooked to the horn cleat on the side of the mast. This gives an 8 : 1 purchase, and should be adjusted to just remove the wrinkles from the mainsail luff. Neither of these controls are essential for everyday sailing, their main purpose being to give more efficient control over the mainsail. Both must be removed when roller furling.

Corsair trimarans are sailed like any other yacht, the most notable differences being the response, lightness of the helm, and the low angle of heel. This ranges from an average of 5 to 10 degrees to a maximum of about 15 degrees.

Pointing ability is excellent, but care must be taken not to oversheet or try to point too high. Just a few degrees less pointing, with sheets slackened slightly, can see boatspeed jump from 6 or 7 knots to 9 or 10 knots.

REEFING

Several different reefing systems can be fitted, and all the control methods are well documented. The roller reefing boom as used on the F-28 and optional for the F-31 is a very effective reefing system, being fast, easy to operate, and infinitely adjustable. It's other main advantage is the ability to easily roll up the mainsail for storage.

To reef, first disconnect the boom vang (if fitted) and Cunningham eye tackle. The topping lift should also now be



Jib barber hauler in use on an F-27 - will considerably boost performance

To reef, disconnect line from cleat, unthread from clew eye, and rethread through new reefing eye. More line will be required and this comes from the excess on cleat

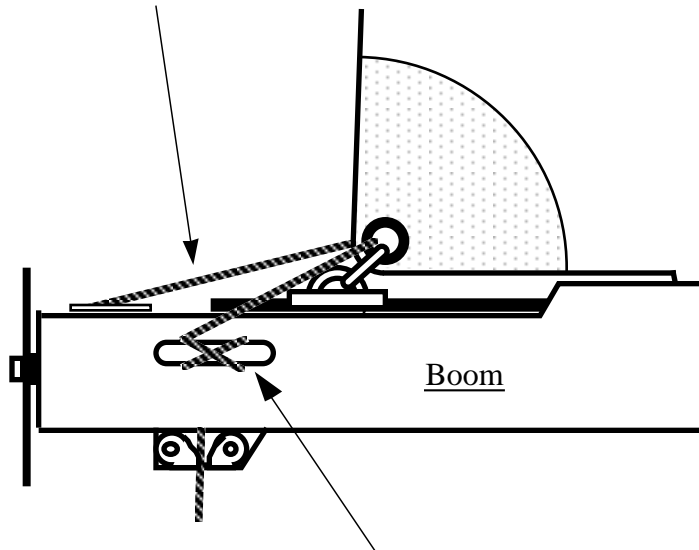

Wrap excess line around cleat so that line emerging from camcleat is not too long.

Reefing eye should also be lashed around mast

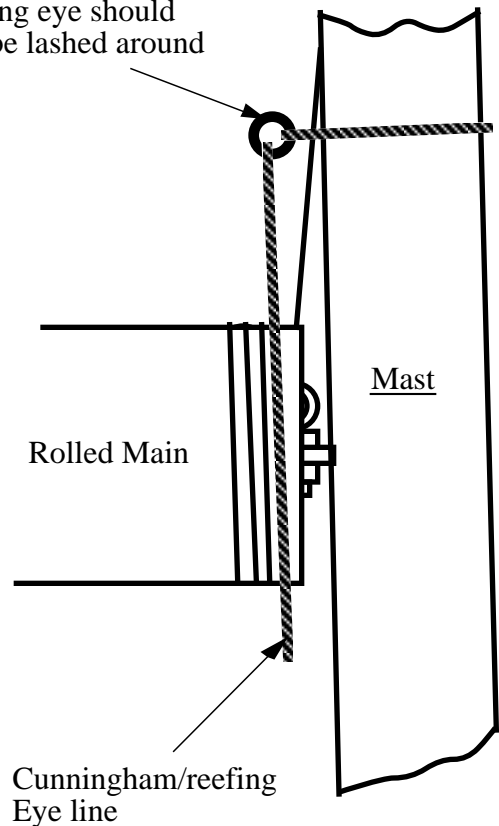

used to lift the back of the boom a couple of inches above horizontal. This stops the main from creeping forward to bind against the mast when furling. This may not be required, depending on the cut of the mainsail.

Now take the main halyard around the winch and release the rope clutch. Go forward with the halyard held in hand, unlock the furling handle and begin turning. As the main is rolled down, let the halyard slowly run out to suit. When the main is rolled up sufficiently, lock the furling handle, let off the topping lift, return to the cockpit and retension the halyard. Reefing is complete.

You should always try to locate the head of the reefed mainsail close to or just above a staying point, rather than in the middle of a mast panel. This avoids unwanted bending loads on any unsupported mast section.

As mentioned previously, if you find a problem with the mainsail rolling up close to and jamming against the mast, this is usually caused by **not lifting the end of the boom sufficiently** with the topping lift.

You may also find it easier to regulate the speed at which the halyard runs out, as you wind the boom, by using the ball of your foot on the line just before it enters the mast.

The boom vang cannot be reconnected, but with the barber hauler system available, if needed, from the floats, this is not of any importance.

A Jiffy reefing system may also be fitted, in addition to the roller furling boom, and this can give slightly better sail control for better sailing efficiency.



Main neatly roller reefed. This F-27 is heading for Hawaii from San Francisco

To use, simply roller reef as described above, but only roll the main up until the selected jiffy reefing points are reached (two sets usually included as standard). Lock the furling handle as before, and then reattach the Cunningham eye tackle to the reefing tack eye.

Now unthread the outhaul line and rethread it through the new reefing clew eye. All the controls of a jiffy reefing system are now in place, except you don't have to tie off the sail it being already neatly rolled around the boom! It is advisable to take a line from the Cunningham eye forward and around the mast. This avoids the possibility of the bolt rope pulling out of the mast groove.

ROTATING MAST CONTROL

The correct rotation of a rotating mast will give a much more efficient and powerful mainsail. It is thus important that the rig not be set up too tight as this can prevent full rotation.

There are many opinions on what the correct amount of rotation should be, but a general guideline is to keep the mast rotated enough to give a smooth, even, transition from the mast to the mainsail on the leeward side.

The amount of rotation will depend on the type and shape of mast, and can range from 35 to 90 degrees from the boat centerline. A good rule of thumb is for the mast to be rotated around 40 degrees more than the boom.



Avoid allowing the mast to rotate or swing back and forth, which can happen in light winds combined with waves, or when sailing off the wind with less sail pressure. This is usually prevented by having the mainsheet angled forward from the boom, which forces the boom forward to keep the mast rotated when pulled tight.

The amount of mast rotation is controlled by a line to the rotation arm on the mast from either the boom or the deck. A line from the boom has the advantage of being self-tacking, by maintaining the mast at a constant rotation angle relative to the boom on all points of sail. However, the control line will have to be detached from a roller furling boom and transferred to an eye on the deck when furling the main.

A control line from the deck is also self-tacking, but it does not automatically adjust for different angles of sail. It will thus need to be let out when bearing off. Some racers like to fit two



lines to the deck, one from each side for absolute control, but this can also be just another complication and is not necessary for general sailing.

WINDWARD PERFORMANCE

All Corsair models will point very high if set up and sailed correctly, but this can also be very dependent on the crew's skill. It is possible to point just as high or higher than an equivalent monohull, but this may not be the fastest way to windward. A good multihull is capable of much higher speeds to windward than a mono, which also brings the apparent wind forward, to where pointing will be lower, but the resultant speed to windward is much greater.

One thing to avoid is over sheeting the headsail, as while pulling this on very tight will guarantee a good pointing angle, the boat speed may be slow. The correct way is to let the sheet out 1 - 2 " from being tight on, so that the curve of the

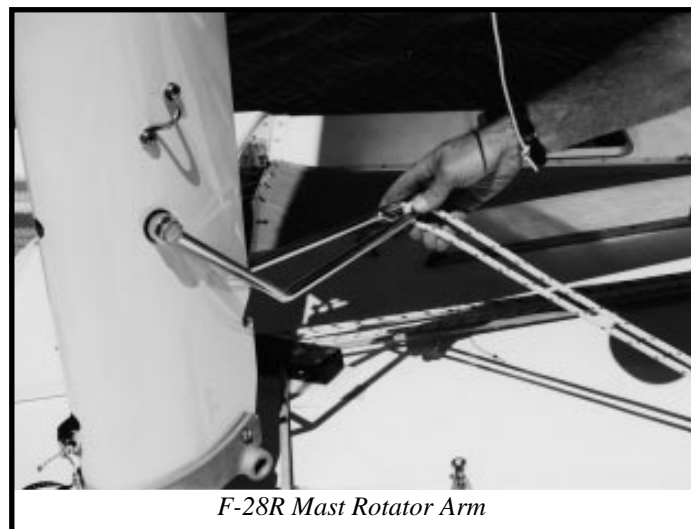



Achieving good windward performance can be very satisfying, but it does depend on a lot of factors being right. Screacher can be left up permanently as shown on this F-28R

headsail leach matches the curve of the mainsail. It should then not backwind the main, and your pointing angle and boatspeed should both be excellent.

Once you have achieved good boatspeed, then experiment by tightening sheets very slightly, pointing slightly higher, while trying to maintain the same boatspeed.

The mainsail traveller should be around 6" to windward in lighter conditions, then around the centerline in moderate winds, and as the wind increases, moved outboard slightly and more mainsheet tension applied. In very strong winds the mainsheet should be pulled on as tight as possible. Stand above it and pull it on as hard as you can - most sailors don't have this tight enough in strong winds. A tight mainsheet helps keep the forestay straight for good pointing ability.

If the jib is backwinding the main, open the slot, by moving the traveller a little more to center. Keeping an open slot between jib and main is crucial to good windward performance, as any back winding of the main will choke the boat. Equally as important, the jib must be relatively flat with NO HOOK in the leach, and not oversheeted. Leach battens are highly recommended to keep the leach flat.

If set up and sailed correctly, a Corsair trimaran will match the windward ability of the best monohull racers, 20 to 30% larger. Pointing high and going fast is one of the hardest

things to achieve in any boat, but with a little care and tuning a Corsair is one of the best.

REACHING

When reaching, it is vital that the mainsail be let out far enough. A common mistake is to sheet it in too tight, with loss of boat speed, a heavy helm and an excessive heel angle.

ALWAYS REMEMBER YOU WILL GENERALLY GO FASTER BY EASING THE SHEETS OUT. PULLING THEM ON TIGHTER IS MORE LIKELY TO SLOW YOU DOWN

Your mainsail should have leach tell tails fitted as standard. Watch these, and should they disappear behind the mainsail to leeward, then you are sheeted in too tight. They should always be flowing aft.

In light winds the mainsheet system can tend to bind and be hard to let out. To overcome this there is sometimes a lever on the side of the camcleat block that disconnects the ratchet. The mainsheet system will then run out easily.

The headsail should also be barber hauled out to the floats when reaching. This is used to get the perfect shape in the headsail (so that it doesn't backwind the main), and will boost reaching performance significantly.

SCREACHER

This is an optional roller furling wire or Kevlar luff

combination genoa/reacher, flown from the spinnaker bow pole. The spinnaker halyard is used on the F-24, while a separate dedicated halyard is used in both the F-28 and F-31R. This allows the screacher to be always left up while furled, ready for instance use.

This multipurpose sail can be a perfect all-around, first choice, additional sail for cruisers, or an essential powerhouse for racers. It is still a developing sail in many respects, and offers some significant and worthwhile advantages.

It can be used very effectively to windward in light airs, and for reaching in moderate airs. It thus eliminates the regular hank on genoa, while providing more sail area, and it is easier to change headsails. The jib is just dropped and the screacher unfurled when required. Sheeting is to a simple strap around the aft beam, which can be moved in and out for the correct sheeting angle.

For the best windward performance, it is very important to keep the luff tight, and many racing owners have even fitted 2 to 1 halyards to keep the clutch loads

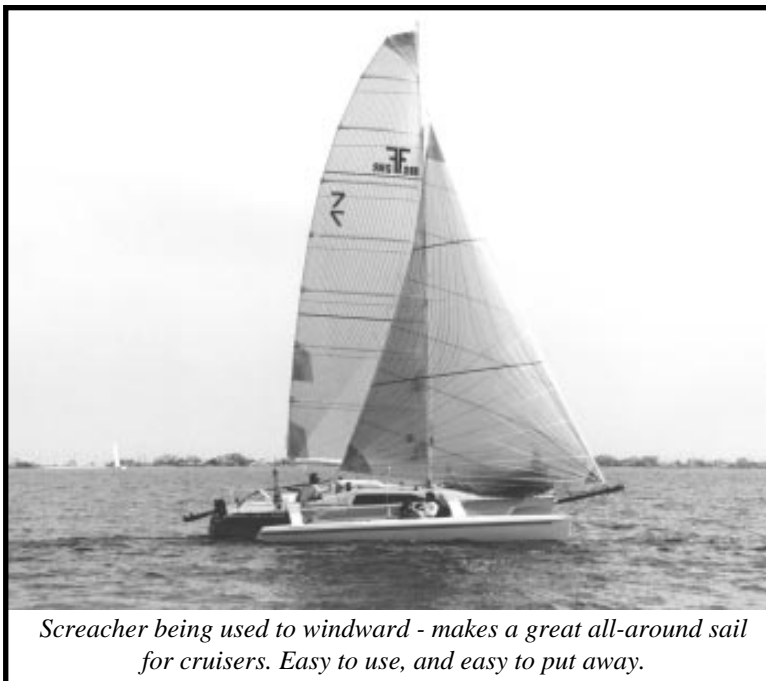

Screacher being used to windward - makes a great all-around sail for cruisers. Easy to use, and easy to put away.



Asymmetric spinnaker on an F-24 Mk II being raced very hard. Note the extra long tiller extensions each side rigged up by these Australian skiff sailors, which are held in place by shockcord to the aft beams. Works very well.

lower. However, the risk of twist when hoisting can then be higher, and cruisers will usually not experience the sort of high loads that some hard racers can induce, in the search for the ultimate performance.

The screacher can be tacked easily when needed by rolling up and then unrolling on the new side.

SPINNAKER

The spinnaker is a very easy sail to use on a trimaran, due to the wide beam and level sailing. The spinnaker thus becomes a very practical and safe sail for family sailing, with very few control problems. The F-24, F-28 and F-31 now only use asymmetric spinnakers, which are the easiest to use, and the fastest if used correctly.

The asymmetric spinnaker can be launched from the leeward wingnet, or main hull bow, and the sheets led back to blocks on the floats near the aft beams for general all round performance. For better pointing ability, particularly when tacking downwind, a closer sheeting angle is better, and the ideal position will vary depending on spinnaker. A block on a movable strap around the aft beam gives plenty of options in this regard.

The tack line is led from a block at the end of the pole back along the main deck to a cleat on the cabin roof at the aft end. To set, connect tack line, sheet, and halyard. Pull on tack line until tack is at the end of pole, hoist and then sheet in.

SPINNAKER JIBING

The asymmetric spinnaker can be jibed either through inside in front of the screacher or forestay, or around the outside. With 'inside' jibing the sheets are run between the spinnaker tack and the screacher if fitted, forestay if not. Outside jibing requires the sheets to be run outside the spinnaker tack.

Inside jibing is probably the most common, as outside jibing does have the risk of a sheet going under the boat,



Asymmetric spinnaker on an F-28R. Jib can be flown inside by racers as shown for better performance in light airs

though this is lessened by using a continuous one piece sheet. The advantage is that the sail does not have to fit through the narrow slot between spinnaker and screacher.

With inside jibing, the skipper should start turning slowly while the crew eases the sheet to keep the sail full. As the clew nears the slot, or the spinnaker starts to collapse, the new sheet should be quickly pulled in to pull the spinnaker through the slot and around, while also releasing the old sheet.

Outside jibing procedure is similar, with the crew waiting until the clew reaches just in front of the headstay, and then pulling in the new sheet, with the sail going around the outside.

In all cases it is very important that the skipper turns slowly, and then heads up to fill the sail before coming to the right course.

SPINNAKER SAILING DOWNWIND

On first using an asymmetric spinnaker you may be disappointed with downwind performance with a fixed mast - unless you take note of what is said here. The asymmetric cannot match a full symmetric spinnaker straight downwind because of the smaller, flatter area, and a restricted ability to

project to windward. The major advantage is considerably easier handling, and a superior reaching performance.

Tacking downwind does not work well with fixed masts, as the mast interferes with mainsail flow, and the main is thus not very effective. A rotating mast is much more efficient and such boats can achieve a very large performance increase, making downwind tacking the fastest way to go.

However, the same effect can be achieved with a fixed mast by using the jib inside the spinnaker which, besides increasing area, helps smooth the flow over the mast and main with spectacular results.

The basic technique/rule is to sail downwind while keeping the apparent wind at about 90°, trimming the sails so they are not stalling or luffing. The jib, for instance, should be sheeted to the float just aft of the forward beam. The extra speed generated will pull the apparent wind further forward, allowing you to go deeper and deeper while maintaining a very high speed. Just keep the apparent wind at around 90°. It can be tricky to get the right angles, but if done correctly, the results can be devastating. So try it! Flying the jib inside the spinnaker may also help improve performance with a rotating mast in light winds.

SAFE SAILING RECOMMENDATIONS

DANGER

Be fully aware that it is possible to capsize any multihull and the following rules should always be observed for safe sailing:

1. Reduce sail early as follows:

- a. Genoa/screacher should be replaced by jib in windspeeds greater than 12 knots.
- b. Main should be reefed to first set of reef points when wind reaches 20 knots.
- c. Main should be further reefed to second reef points when wind reaches 25 knots.
- d. In winds over 35 knots main should be roller reefed to 4th batten from the top and jib replaced by storm jib
- e. Over 50 knots, main should be furled more, or completely, leaving only the storm jib.

If necessary, all sail can be taken off and a properly set up Storm Parachute Anchor put out. This is now a well proven method for a multihull to survive even the worst offshore

storm. It appears to virtually eliminate the danger of capsize from both extreme wave action and hurricane force winds.

Other variations of the above are possible depending on the circumstances. Experienced and alert racing crews can delay reefing to even well beyond the above limits.

A quick way to reduce sail, and achieve a very comfortable and safe motion is to simply drop the jib and sail under main only, reefed if considered necessary. This avoids the need to tack the jib, and the fully battened main remains docile and easy to handle.

Sometimes, when running downwind, it is better to drop the main and run under jib only. Corsair built trimarans can go to windward and tack while sailing under either jib or mainsail alone.

2. When winds are strong and gusty, and the boat is being sailed hard, then **always have the sheet of the largest sail up, be it the mainsail, genoa, or spinnaker, in hand, ready for quick release.** Use only the camcleats provided and **never use self-tailers** as cleats in high winds - they are too difficult to release fast.

Always be ready to release the sheets if you feel the boat is being pressed too hard. Instruct your crew to do likewise. If concerned, then just reef until you are comfortable.



This is definitely not safe sailing with a novice crew aboard! The F-27 shown is sailing in 30 knots with full sail, and an experienced crew. Boat speed reached 23 knots. Note how the main hull bow stays high, while the boat planes on the aft sections - this is an important safety characteristic of all Farrier designs. It is very hard to bury the bow. DO NOT do this sort of thing with your family on board. To be safe, always reef early.



For safety, always wear a life jacket, and, when sailing hard, always keep the sheet in hand ready for instant release

DANGER

Never leave the sheets unattended, if un-reefed and the wind is exceeding 20 knots.

If being pressed while reaching then it is better to **bear away downwind** than round up. The boat will slow down, and the mast momentum from the turn is to windward, reducing heel. Round up and speed may increase surprisingly, while mast is thrown to leeward, heeling the boat more.

The only time to luff up is while hard on the wind (do not bear away in this case), feathering the sails until any gust passes by.

In general, your visual indication of being overpowered is when the leeward float is pressed far enough down to have waves regularly wash over it. If cruising with your family, then you should reef before this for the best comfort. If sailing for speed, this is not of great concern, providing the crew is vigilant, and this sort of sailing has been done for hours at very high speeds.

It is not unusual to drive the low resistance float bows through waves, or even submerge the float in some circum-

stances. This has been found to have no adverse effect on the boat, and in fact the boat will tend to round up slightly, not slew to leeward as commonly and mistakenly believed. Early Farrier designs used low buoyancy floats, and frequently completely submerged the leeward float, with speeds in excess of 15 knots, for quite some time, with no ill effect on the boat. However, this is sailing on the limit, and don't push your luck unless prepared for a ducking.

3. Beware of being caught side on, with little speed and with all sails sheeted in tight. This can happen after a tack if concentration is lost.

4. If caught in a severe thunderstorm, a simple safety procedure is to drop all sail and simply let the boat drift. You will lie side on to the wind which is quite safe, unless the waves are very large, in which case you should steer off downwind. Corsairs will steer quite well from a reach to a run with no sails up in any winds over 5 knots - try it sometime. It is even possible to round up into the wind.

5. Another safety procedure in a severe storm is to simply

drop all sails and anchor, which is probably not used enough as a safety procedure. It is very effective. At sea a Storm Parachute anchor has the same effect.

6. Always listen to the latest weather forecast before you set out on any sailing trip.

7. Always leave yourself a large safety margin, be it while sailing, or simply motoring around.

8. Always carry full safety gear, including life jackets, as required by U.S. Coast Guard and local regulations.

The above procedures will give a high margin of safety and should always be observed whenever safety is paramount. If absolute performance is required, and an experienced crew is aboard, the above limits can be comfortably exceeded. In some earlier sea trials full sail has been carried in over 40 knots of wind, including the spinnaker. This is not for the inexperienced however, and any skipper doing such sailing must be prepared for and accept the responsibility for the extra risks involved. It should not be done offshore.

SAILING HINTS

Corsair trimarans have several unique sailing features, one of these being the ability to make continuous 360 degree turns in the one spot. To do this, while going to windward for instance, just tack, but don't touch any of the sheets. You will continue to turn, jibe, and tack again indefinitely. Can be a handy tactic on starting lines.

A simple way of heaving to, is to just tack as above, but immediately put the helm over to turn back into the wind, with the jib sheeted on the windward side. This prevents tacking again and the boat will instead fall off. The rudder then takes over again and turns the boat back into the wind. You will then stabilize like this, just off the wind, moving forward very slightly. The helm can be lashed over and you now have a stable, barely moving work platform to do any needed repairs, stop for lunch, or just wait for someone else to catch up!

Should you ever loose the rudder, for whatever reason, don't despair. Among the repertoire of tricks is the ability to sail without the rudder. It takes a little practice to get right, and it is worth practicing sometime. Pull the rudder fully up (first making sure you have plenty of room!). Now, to go to



Set up and sailed properly, a Farrier design is a very safe, yet very fast boat. This F-31 is powering into 25 to 30 knot winds, with a single reef. Speeds of around 11 knots to windward are possible in such conditions



*When seeking the best performance, keep things in perspective - there will always be some boats that will be faster...
Sir Peter Blake's 60 foot trimaran Steinlager and an early Farrier design - the Trailertri 680.*

windward, you sheet the jib or genoa as per normal but let the main right out. Pull the main on slightly and you will begin moving. Pull the main on more and you will come higher, let it out and you will go lower. Pull the main hard on and you will tack. Immediately let it right out until you stabilize on a reach, and then start pulling it in until you are going high again.

This takes a bit of practice to get it right, and for a time you will be all over the place, but after a while you should be able to work your way to windward, tacking too, just by adjusting the mainsail.

You can also sail surprisingly effectively without any sails. The mast alone is sufficient to get steerage way downwind, and once moving you can bring her up on to a reach, even back into the wind. This can be a handy feature for coming into a ramp or dock at a greatly reduced speed.

Another feature is the ability to back up. This takes a bit of practice, but by turning into the wind, and waiting until she starts going backwards, you can control this backing for as long as you want. Just steer the rudder whichever way you want to go. Can be useful in backing off a beach, or away from a dock - just let her go back, swing around once in clear water, and then accelerate away.

The high potential speeds possible with rotating masts off the wind can be intimidating to new multihull sailors, and, if necessary, the potential speed can be reduced to a more

comfortable level by reducing sail or by under rotating the mast, which depowers the mainsail. More rotation can be used as one becomes comfortable with the speeds possible.

When spinnaker running before very large seas offshore, with boat speeds of 20 knots or more, there can be a danger of pitch poling. This can be caused by pressure from the mainsail which cannot be released downwind should the bow dig in. The **solution is to drop the mainsail**, which virtually eliminates this risk. This rule only applies to racers, as cruisers should have reduced sail well before this even becomes a danger.

The limit for racers with modern rigs will always be nose diving, though this is hard to do with a Farrier design, due to their characteristic 'high bow' sailing stance. The F-28, for instance, at speed, frequently has the complete center hull bow section out of the water, the waterline beginning just in front of the daggerboard. This comes from the wide flat swept up aft sections of the main hull which generate negative lift, actually sucking the stern down.

This characteristic can be maximized when needed with high speed racing downwind, by moving the crew inboard and aft to the back of the cockpit. This keeps the flat aft sections of the center hull in the water and the bows very high, by increasing the negative lift at the hull aft sections. This works most effectively on aft cockpit rotating mast

boats, where the heeling component of the sails is less than the fixed mast, the drive being angled more forward.

Also important for the best performance, by minimizing wetted surface area, is to move crew weight well forward in light to moderate winds, to keep the bows down, countering the stern negative lift.

The boat should also be heeled to leeward (crew on leeward side) when sailing to windward in light winds, just as with a mono. This keeps the sails in a more efficient shape.

ANCHORING

Trimarans tend to be lively at anchor, due to their light weight and shallow draft. They like to sail from side to side, which can be annoying. This is simple to overcome by using a bridle setup to each float bow. These have eyes fitted as standard, for a block to lead the bridle lines aft.

When anchoring, just lay out your anchor as per normal, over the main hull bow roller. Set up the rope bridles, running through the blocks on the float bows and back to the spinnaker coaming winches. Bring the 2 bridle lines together in the center of the boat and attach to the anchor line. Let the line out further until the bridles take over the load. You will then have a well behaved boat.

BEACHING

One major multihull advantage is the ability to come right

into a beach. You can either pull in far enough so that the boat cannot move around (which can wear out your expensive bottom paint) or anchor just far enough out so that the boat remains floating in 2 or 3" of water.

RETRIEVING TO TRAILER

After sailing is finished, the jib is dropped and the mainsail is roller furled or folded. Remember to **lift the boom aft end** as required with topping lift for smooth roller furling. Once fully rolled, you should then hold the mainsail with one hand, and **reverse wind the boom** with the other. This loosens the tightly rolled main, preventing any wrinkles, and relieves any bending force on the battens.

The floats can be folded before arriving at the ramp for reduced beam, and this also allows the float bows to be very useful step-off points, if needed. Use the secondary wider folded position on the F-31 if windy and there is still some distance to the ramp.

Prior to folding, with all rotating masts, the mast raising wires must be fitted.

WARNING

Rotating masts must be supported by raising wires before disconnecting shrouds, or mast could fall

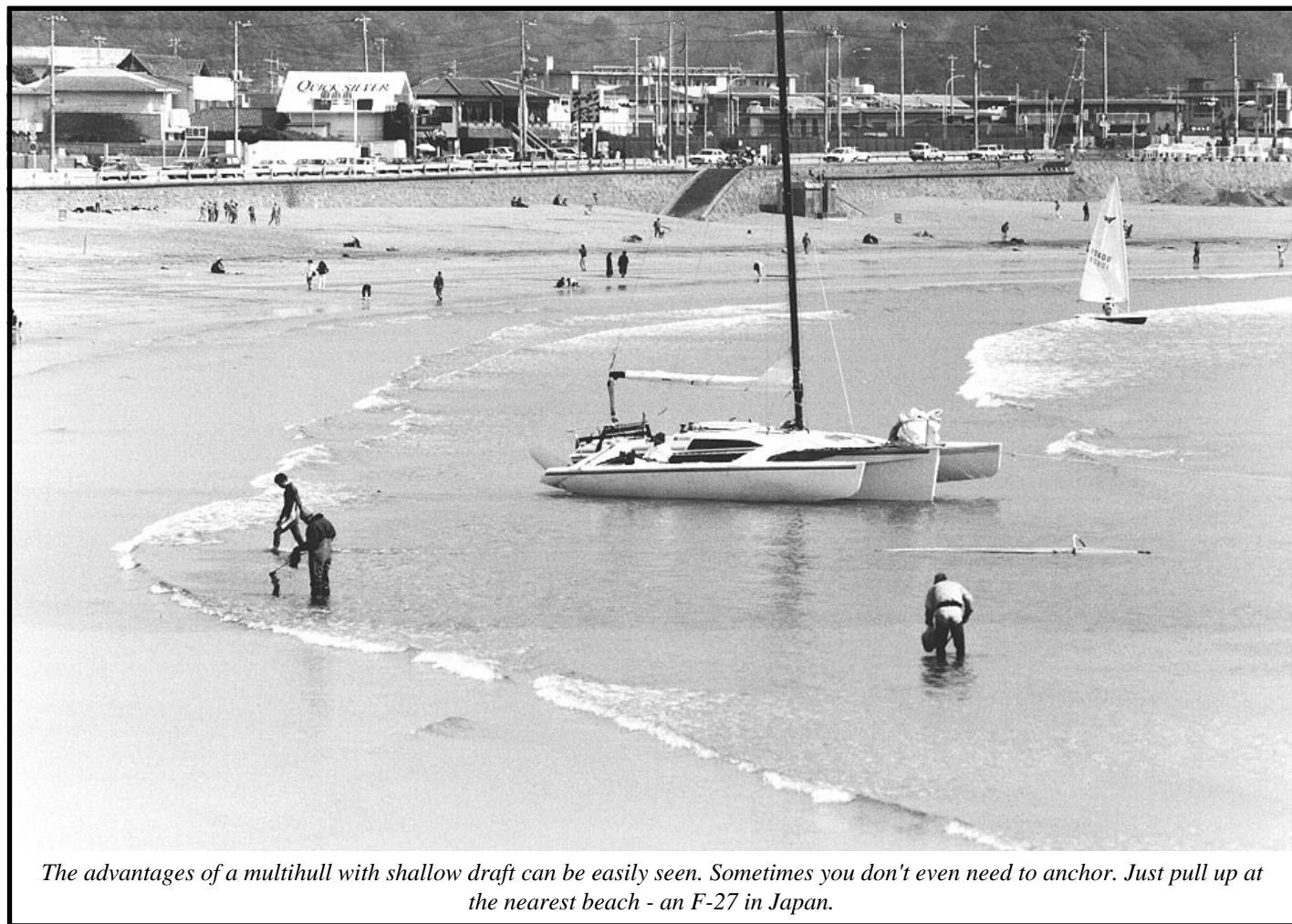

The advantages of a multihull with shallow draft can be easily seen. Sometimes you don't even need to anchor. Just pull up at the nearest beach - an F-27 in Japan.

To fold, disconnect the shrouds from the float chainplates (not required with F-24). The shrouds are then retained to the float by the Link Plates with rotating masts, which give just enough slack to fold, while preventing the mast from falling should the mast raising wires be forgotten.

The F-31 fixed mast version will require that the shrouds be completely disconnected from the float, and they can then be secured to the mast with velcro straps. This stops them from flopping around. An alternative is to attach them to the float deck just behind the forward beams. This keeps them from moving, yet allows the float to fold up.

Before folding, first check to see no one is on the side being folded, and then undo the beam bolts. The beams on the side first released may spring about 12" into the air as the last bolt is undone. Hold the top of the beam and lift upward to fold, **TAKING CARE NOT TO LET THE FLOAT SWING IN TOO FAST AGAINST THE CENTER HULL** which could damage the stops. You will have to slow it slightly. Insert the beam locking pin. If the float does not fold in fully, the usual cause is the wingnet catching on the aft corner of the cabin

side rail. To correct, just push the wingnet down under the cabin side rail.

WARNING

Take great care while folded in winds of 25 knots or more. A combination of a high cross wind and a fast, tight turn, may be sufficient to overcome the folded stability of bigger designs, resulting in a roll over.

Now fold the second side. You may find this initially more difficult, as the boat is heeled this way, due to the first float folded lifting that side. Crew weight on the already folded side will help by levelling the boat out more. Lift, and once again don't let the float come in too fast once it starts moving. Insert the beam locking pin.

If anything seems hard or difficult when folding, STOP and see if anything is misaligned, or snagged. A common error is to try and fold without disconnecting the shrouds. The beam won't budge, so remember to check this.

Raise the daggerboard and rudder, and cleat both in the up position. You are now ready for the trailer.

If there is a cross wind at the ramp, then a Side Guide Rail should be fitted to the leeward side of the trailer. This will prevent the boat swinging sideways and off the trailer.

Back the trailer down into the water until the water reaches the forward inward bend of the trailer side members and the float supports are just visible above water level. Don't submerge the trailer any further than this. Gently guide the boat into the center and pull up as far as it will go. Take care here, that it comes on straight, and avoid pulling it over the center hull side supports, as this can damage the Log paddlewheel sender unit on the bottom of the hull (gets expensive to replace).

A side line from the windward aft cleat may also be helpful in cross winds to prevent the stern swinging too far sideways.

If motoring onto the trailer, **leave the daggerboard down until the last minute** - otherwise any crosswind makes it very difficult to keep on center. Once fully on, connect the trailer winch hook, and winch on the remaining few feet.

The boat can now be pulled from the water, and when on level ground remember to check that it is fully winched on. Once out of the water there always tends to be some slack in the winch wire. **Tie an extra safety line** from the bow eye down to the winch post, ready for de-rigging.

DE-RIGGING

Remove the bow line, separate the two lines, and use as the side tie-downs. Fit the aft mast support and the trailer lights.

Remove the jib and fold. The jib sheets can be stowed in the anchor well ready for instant use next time. If possible, the jib can be stowed inside one of the



*F-28 Shroud disconnected, and being restrained by link to give just enough slack for folding. Mast raising wires **must be fitted prior to disconnecting shroud** (can be seen in background).*



This is about the right position for the trailer when retrieving

reaches the aft mast support.

CAUTION: If your trailer winch does not have an automatic brake feature, **don't let go of the winch handle while lowering.** Should this happen it will start spinning very fast and could cause injury. Don't try and stop it - except by using the winch brake. **DON'T try and grab the handle** - you will just have to let the mast fall - better than a broken hand.

Once the mast is fully down, disconnect the winch hook, reconnect to the bow eye, and re-tension. The jib halyard is then reconnected to the mast.

Disconnect mast from the step, and lift it up to enable the wind indicator to be removed from the masthead. Walk the mast forward until the mast can be mounted on the pulpit's lift up spigot (in roller furling shaft hole)

floats - thus keeping it from cluttering up the main cabin.

If possible, relieve the tension on the battens, and these can be left in the loosely rolled main. Remove the roller furling handle (if fitted) and stow in the anchor well. Leave the topping lift on, to take the weight, and disconnect boom from the mast. Lay it down on the cabin roof to one side and fit the sail cover/bag. Disconnect the topping lift, and reconnect to the mast.

The boom/mainsail is heavy on the F-28 and F-31 and hard to handle. It can be stowed in the cabin if you wish, but this takes considerable effort, and room inside. It is much more convenient to stow it on the cabin roof, where it is protected by its bag and is ready for instant use next time.

To lower the mast, release the jib halyard from the rope clutch, turning block and mast base block (if necessary) and **cleat it to a horn cleat on the mast side.** Release the trailer winch hook, pass it over the bow roller and hook to the jib halyard. Tension the winch until the forestay just becomes slack, allowing the pin to be removed. There is no need to slacken the turnbuckle.

Take the forestay back and secure to the mast. Remove all halyards etc. from the rope clutches and blocks as required. Wrap these around the mast to retain all stays and halyards neatly against the mast. It is important that this is done now, otherwise when lowering the mast any loose stays will tend to fall away over the boat. It also makes subsequent rigging easier.

Fit the mast raising pole/yoke assembly, and begin lowering the mast by letting out the trailer winch line. **The raising wires must be fitted with rotating masts.** As the mast comes down, take care that the winch line meets the center of the raising pole, and that the mast is central when it

or rested on the carrier on the pulpit.

Secure the mast to the pulpit and aft mast support. All rigging wires and stays should now be secured to the mast with the Velcro ties. This is to prevent them from rubbing on the deck which will quickly wear through any gelcoat or paint. On long trips it is also a good idea to pad between the wires



Fitting an F-28 Mast to pulpit. All such masts with roller furling fit on a vertical 'swing up' spigot on the pulpit. Mast raising pole yoke can be left on mast as shown if wished. Note also rotator position - folded up against mast.

and the mast, or remove the wires altogether.

CAUTION

Do not use elastic cord type ties on the mast, with hooks, as they can be dangerous by whipping back and causing eye damage.

Rudder should be fully up, and tied to one side. Should local regulations not permit the rudder to be left on the transom, it should be removed and stowed in the towing vehicle. If fitted, secure the pop-top down, or it could lift up during high speed towing.

Connect the trailer lights (making sure they are on the correct sides) and then check that the trailer is correctly positioned under the hull. You are now ready for the road.

LIFTING OUT

Should there be no ramp present, then all Corsair models can be quite safely lifted in and out by the usual dockside lift, using the optional and permanent **Lifting Eyes**.

Slings can also be used around the complete folded craft, the best bearing areas for the slings being the beam areas. Other temporary lifting points are the mainsheet traveller (outer corners), shroud chainplates on the center hull (when fitted), or the beam bolt pads in the beam recesses.

MARINA DOCKING

For marina docking, the shrouds are released from the

floats and the floats folded as normal. The marina slip can then be entered and the folded boat moored as with any other craft. However, care must be taken if high cross winds are a possibility, as **folded stability is limited**. Precautions include running a line from the mast to the dock on each side, a wider folded position, or lowering the mast in extreme conditions. Folded stability without the mast is very good, and the folded boat can actually self right up to even a 80 to 85° heel angle.

One problem with marina docking is oil stains or growth on the lower float sides. This is not a major problem with short stays in a slip, but will be a nuisance over a long period. There are several ways to overcome this, one being the use of an antifouling wax on the float sides. Thus the gelcoat finish is preserved and only an occasional wipe is needed. Antifouling paint could also be applied to the float sides but this is not attractive, it needing to be 2' 6" wide.

One of the best and recent solutions for long term Marina docking is a dock liner, which surrounds the boat with sterilized water, preventing growth.

* * * * * **SAFETY** * * * * *

The modern trimaran with its enormous stability and unsinkability is a very safe craft, and has now established an excellent safety record. However, this safety is dependent on the operator and how the craft is handled.

The major hazard to be avoided is capsize, and a few simple rules make this virtually impossible. Capsize is rare



*This is **not** a safe angle of heel - go this far and you are probably gone! This F-27 is being pulled over to test stability.*

with well sailed cruising multihulls, but can occasionally occur with racers pushed to the limit - just like race cars. The important factor, as with a car, is that the degree of risk is up to the driver/skipper. Drive/sail too fast for the conditions and the risk of a crash is higher. **The decision is yours.**

It is not taken away from you by a heavy keel below, making it impossible to go fast. Nobody seriously suggests weighing down a car to prevent a roll over, nor should a sailboat be weighed down to limit performance, just because a few may not have the maturity to sail a fast type of craft safely.

Thus, like a car, a multihull has the capability of very high speeds when desired, and the risk factor can consequently be higher. The choice is yours however, as it is **not compulsory to go fast**. In general, the risk factor will only begin to increase when boat speed exceeds 15 knots while reaching, or about 8 knots to windward. When sailed for the conditions, or with safety in mind, Corsairs are the safest craft afloat.

UNSINKABILITY

This is the ultimate safety feature for any boat. All Corsair models are unsinkable, being constructed almost completely in foam/glass, with multiple watertight compartments. With no heavy keel, it is therefore immune from sinking, even with all watertight compartments flooded. No matter what happens, you can be assured that your Corsair will always be there, and will never go aground in 200 feet of water!

There are up to 12 watertight compartments, depending on the model, including:

Floats: 3 compartments each.

Forward berth: an important factor against collision.

The four beams: up to 170lbs buoyancy each

OFFSHORE SAILING

All Corsair models have been designed strong enough for heavy weather sailing, and both the F-27 and F-31 have now crossed both the Atlantic and Pacific Oceans many times. However, it should be noted that they are small boats for such long offshore passages, and for this reason such voyages **are not recommended**.

Due to the considerable wear and tear that can result from such voyages, and the many unforeseen hazards, warranty



Even when fully flooded, a Corsair will stay afloat easily. This F-27 was deliberately flooded in order to demonstrate its unsinkability.

coverage is not available for any boat undertaking any passage offshore longer than 200 miles.

******* WARNING *******

THE SAFETY OF ANY CORSAIR MODEL AT SEA CANNOT BE GUARANTEED AS OFFSHORE SAILING CAN BE A HAZARDOUS UNDERTAKING, WITH MANY RISKS. NUMEROUS FACTORS BEYOND THE CONTROL OF THE MANUFACTURER WILL AFFECT THE SAFETY OF ANY OFFSHORE VOYAGE AND ANY OWNER TAKING A CORSAIR TRIMARAN OFFSHORE MUST ACCEPT FULL RESPONSIBILITY FOR ANY RISKS INVOLVED.

It is not within the scope of this manual to go into all the necessary equipment for offshore sailing, this being covered by many readily available books, and/or offshore safety regulations. Essential items are an underwing re-entry hatch, the optional Storm jib, and a properly set up **STORM PARACHUTE ANCHOR**. The parachute anchor is a recent development for multihulls and offers a very comfortable and safe method for surviving severe storms.

CAPSIZING

Capsizing is always a possibility, even if a remote one, and should it ever occur, stay calm, and make sure all crew are accounted for. Anyone inside can stay there, it being safe for some time. There is no danger of sinking.

When sailing offshore the following items should always be stored in the safety compartment (accessible from under-

neath if capsized), with lanyards attached, and in watertight bags:

EPIRB unit	Cutting Tools
Extra wrenches & tools	Bolt Cutters
Spare Beam Bolt Wrench	Ropes
VHF Hand Held Radio	Pliers
Copy of Righting instructions	Flares

Surge is the major enemy inside the boat, and the first priority should be to seal all hatches, vents etc. and try to keep the boat dry as possible. Pop-top will remain in place as this will try to float upwards. Main battery switch should be turned off and all loose objects stored in the cabin settees, these now being above water. Surge will otherwise remove everything. Water level while inverted is around the bottom of the beams - float decks are only just immersed.

If possible, the battery should be removed as it will discharge under water. It should be a **sealed unit** thereby eliminating the danger of acid or gas.

If offshore, the crew outside can use the recommended re-entry hatch to shelter inside, or if not fitted, obtain a cutting tool from the safety compartment, (accessible while inverted) and cut an access hole into the hull under the cockpit

storage lockers.

You now have a large, relatively comfortable life raft, and well stocked with provisions. Much better off than in a small liferaft with minimal provisions. In fact the record for the longest survival time adrift at sea is now held by the crew of a trimaran capsized off New Zealand in 1990. They were in such good condition when rescued that their story was first believed to be a hoax. The same year an offshore racing monohull disappeared off Australia, taking 6 lives. Had they been on an unsinkable trimaran, the crew may have survived. Modern satellite position indicating systems now offer very quick and easy location for a floating, but disabled multihull, whereas a sunken monohull has no such option.

RIGHTING

Righting at sea, unless outside help is available, is probably not a feasible option as yet. Probably better to leave the craft as it is, where the crew are safe, and await rescue.

When the opportunity arises, and outside assistance is available, the most successful system for any multihull, is to tow the capsized boat fore and aft, the tow line going to the aft end, in the form of a bridle. Which end depends on the boat, but the general rule is to choose the end that is floating

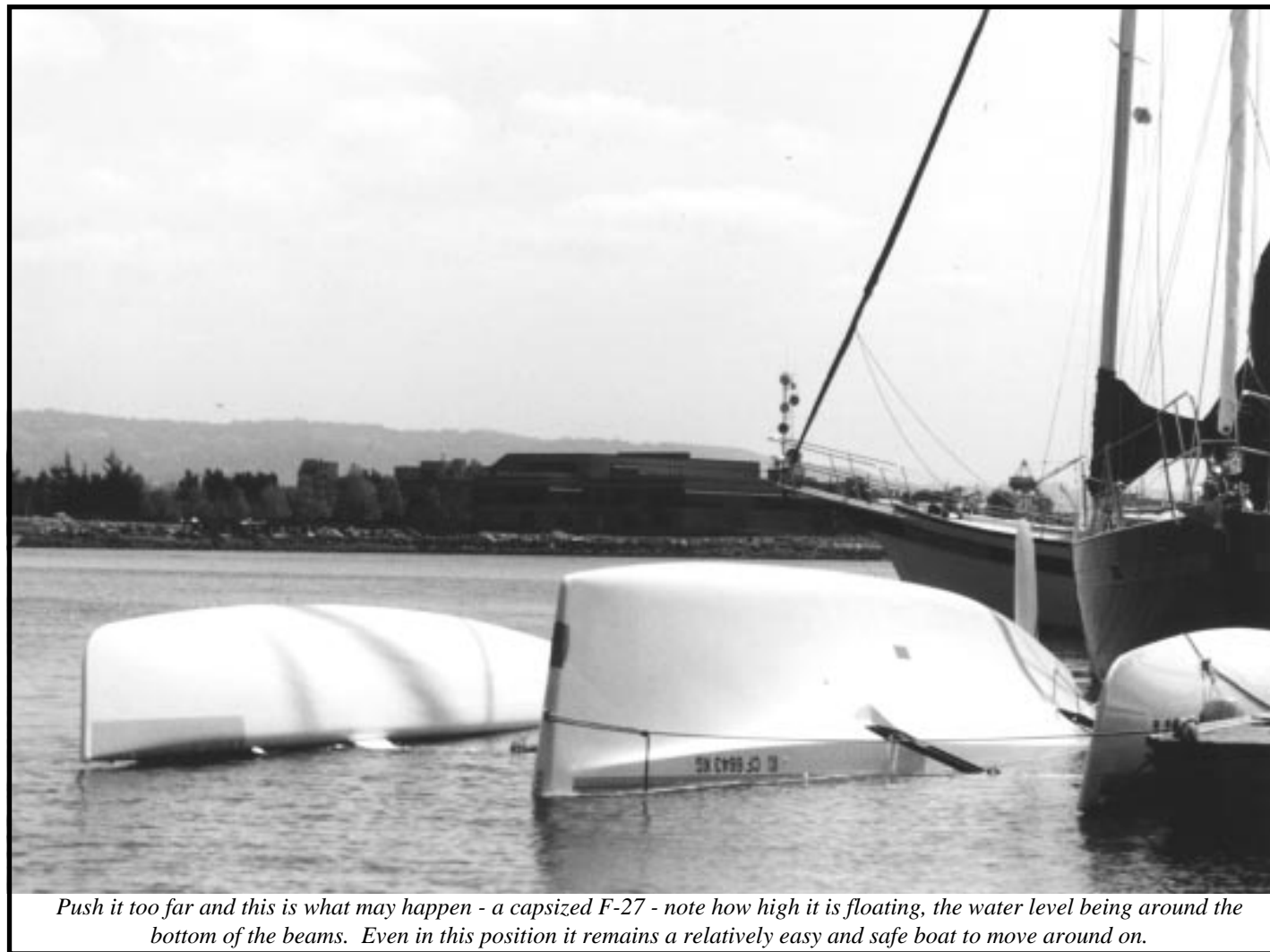

Push it too far and this is what may happen - a capsized F-27 - note how high it is floating, the water level being around the bottom of the beams. Even in this position it remains a relatively easy and safe boat to move around on.



However, the cleanup work required is not so easy - the same F-27 just after righting- looks a mess right? Well sail sensibly and don't even risk a capsize - it is easy to avoid

highest. Thus as the boat begins to move, the lowest end, be it bows or stern, will begin to sink, and even more so as the water inside rushes forward. The boat should then flip back upright, bow over stern or visa versa.

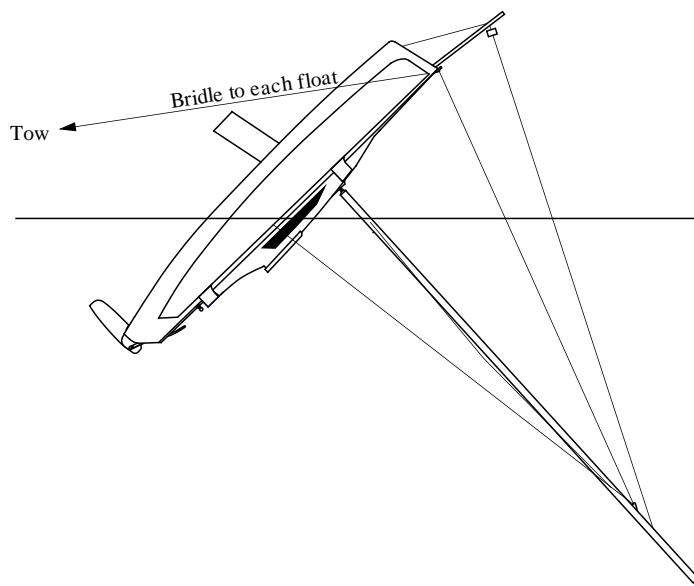

If the above procedure does not work, then try flooding the end that needs to sink, or add some crew weight (ready to abandon ship once the end concerned starts to go under). If this fails, try towing the other direction. Some controlled

flooding may also be required. Towing sideways will not work.

Another righting method, that uses the folding system, has been tested and shown to be workable on a Farrier designed 19' Tramp in choppy conditions, and on an F-27 in smooth water. The Tramp was deliberately rolled over, the F-27 was a capsize.

The method has not been successfully tested at sea and thus should not be tried at sea, it being better to wait for assistance, as the righting action does tend to flood the inverted boat more. Not a good idea if the righting attempt doesn't work.

The F-27 capsize was caused by the spinnaker combined with a mainsail sheeted tight amidships (never do this while under spinnaker in any circumstances). Both sails were being carried in winds gusting to **35 knots**, with **NO ONE** holding the sheets. Crew was just owner and 10 year old daughter. Boat speed was over 20 knots and the capsize happened while changing from a run to a reach, and the crew were not able to release the sheets in time. **In these conditions the sheets should always be hand held without exception.** The spinnaker sheet can be easily led to the windward jib sheet winch, making this very easy to do.

After capsize both crew surfaced under the wingnets, but found plenty of space to breathe due to the high floating position. There appears to be little danger in being trapped

here. They were then able to get on to the upturned boat (now a safe 19' wide raft), which was towed ashore, and righted, with relatively little damage, the next day.

The procedure using the folding system is as follows:

1. Put on a lifejacket - this is essential for easy working in the water.

2. The boat will be floating side on to the waves, and you should first attach righting ropes to the windward float beam areas and bring them over the main hull to the leeward float. Use a pair of lines for each available crew member.

3. Disconnect and save both shroud tensioners if fitted, which can then be used to help as necessary.

4. Release top shrouds from the float chainplates, and allow to drop with fixed masts. Secure a line from the leeward shroud, with rotating masts, to the leeward float.

5. Connect a line to the forward beam area on the leeward float and connect this to righting line from other side using 4:1 shroud tensioner.

6. Release all beam bolts. This can be done while alongside without diving. The bow nets may have to be unlashed to reach forward beam bolts.

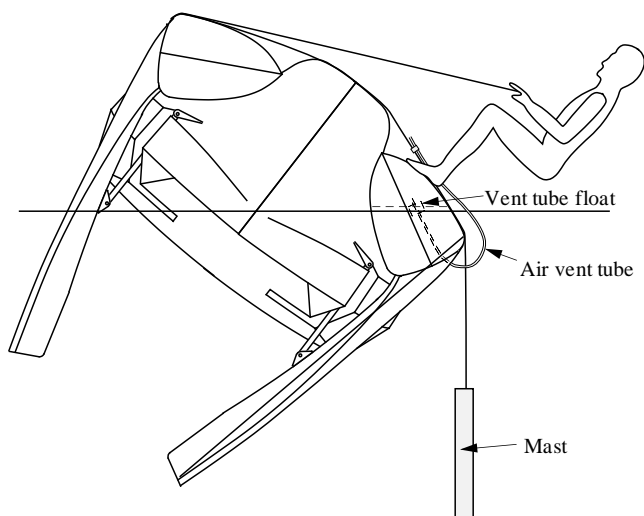

7. Stand on the wingnet and pull on the shroud tensioner. The float on the side you are standing on will fold up, your weight helping. Once folded, insert the beam locking pins. Repeat process with other side float. Smaller designs will fold up just from your weight on the wingnet.

You now need to drop the mast off, and use its weight to assist righting, by helping the hull to rotate in the direction desired. This is done by hanging it from a line passing over the leeward float, and attached to the windward float.

If in sheltered waters, damage to mast can be minimized by pulling back to the trawling position. However, outside assistance will probably then be needed to rotate the boat.

8. Release the forestay, attach a line, and take to the center of the leeward float. Run the line over the center hull to attach to the windward float deck eye just in front of the deck hatch.

9. Release all halyards from the rope clutches, and unthread from the turning blocks.

10. Release mainsheet from traveller, the jib sheets, jib tack, inner forestay (if fitted), and any remaining shrouds.

The mast will now drop, or hang from the step pivot pins with fixed masts, which will soon break from the motion of the unsupported mast. If not, then remove the nuts of the deck pivot brackets from inside. Mast will now hang from the leeward float.

11. Open all hatches on the leeward float, and stand on the float, stabilizing yourself with the righting ropes, to the windward side. The float will slowly start to flood. If necessary small holes may be required on the highest part of the float side to let out trapped air, or a simple vent tube from this area to the atmosphere will allow the air out.

12. As the float floods, start rocking back and forth in time with the waves. Once the float is flooded sufficiently, the boat should roll upright. It's possible to climb around the boat as it rotates to end up on deck. The beam retaining pins will fall out and the floats will tend to unfold themselves.

Now tighten the beam bolts, and start bailing. A long tubular type bilge pump is needed to do this successfully. You may initially need to wrap a rag or towel around its body where it enters the circular float hatch to prevent water reentering. Pump should always be secured so that it cannot float away.

If you find your weight is insufficient to cause righting, then additional weight such as the outboard motor, or battery can be sent down the mast line to assist. If assistance is available, then a tow sideways will help - and this is the only situation where a sideways tow will work.

The mast may or may not be salvageable, depending on the number of crew available.

PERSONAL RESPONSIBILITY

There have been exhaustive efforts to minimize the risk of personal injury, loss, or any other form of damage, while operating a Corsair built trimaran, but obviously it is impossible to completely eliminate every risk. Winches cannot be made trip proof, nonskid can wear and cause slipping, rigging wires can be kinked while rigging and later fatigue, lifelines can be fallen over, frequent groundings at speed can cause eventual daggerboard or rudder failure, neglect of proper maintenance can cause early failure, and lack of experience can cause accidents in congested areas, or bad conditions. Sailing can be hazardous at times, and the boat operator should accept responsibility for all such hazards

Many of these risks have been covered in this manual, but obviously it is impossible to cover them all. Some recommended procedures may not even be the correct ones in certain situations. The operator should therefore always be vigilant against all possible safety hazards and correct or warn the crew against any possible danger immediately.

SAFETY IN GENERAL

*Capsize matters can be depressing, but **to put it in perspective**, a capsize is simply very difficult to do. Luffing up slightly, or **bearing away** (if on a reach) is usually all that is required. The risk of capsize can be virtually eliminated simply by **reducing sail according to the conditions, and being prepared to let the sheets go**.*

When under spinnaker in winds of over 20 knots it should always be a matter of policy to never leave the spinnaker sheet unattended. It should be hand held, not even cleated. Cruisers shouldn't even use the spinnaker in over 20 knots. Under main and jib you can still reach 15 knots, with complete comfort and safety.

*Fortunately it is very hard to capsize a Corsair trimaran, but this can lead to overconfidence. Don't fall into this trap - always be aware that it is possible to capsize, and reduce speed accordingly **to suit the conditions** - just like any car.*

TECHNICAL NOTES

WINCH LINE

The trailer winch line should be regularly replaced. This tends to wear quite rapidly and is under a high strain when lifting the mast. A breakage here could be very dangerous. It is always advisable to stand clear of the line while lifting the mast. Also, frequently check the trailer winch line is tight when on a long trip.

SPRING RETAINING CLIPS

CAUTION: The spring retaining clips as used on the Turnbuckle clevis pins should be regularly checked to ensure they will still 'clip' fit on the clevis pin. Replace if they have lost their spring and become loose, otherwise you could lose your mast.

These spring clips have been used successfully for over 20 years and are intended as a convenient 'quick rig' feature. They are not as secure as a properly fitted cotter pin, and if any doubts exist on their use then a cotter pin or circular ring should be used instead, and a few of these are usually included in the Toolbox. However these rings or pins will increase rigging time, and the final decision in this regard is for the owner.

LAUNCHING

If immersing the trailer to the bend in the frame will still not let you free the boat, be careful; a few inches more can have your boat drifting away, so have a bow line secured.

BEAM BOLTS

These should always be in place and tightened before going sailing. Otherwise the Upper Folding Struts can again be overloaded as above, due to the beam inner end being forced up slightly by sailing loads.

It is also possible, but unlikely, for a Beam bolt to gall and seize in a bolt pad, which can prevent you from folding up the

boat. If this happens, then you can still fold up the boat by simply releasing the bolt pad nuts from inside, or cutting off the Beam bolt head. To avoid this, keep the threads well lubricated with a Teflon grease.

HOISTING MAINSAIL

If you find this is tight going up or down (a not uncommon problem with full batten boltrope mains), there are now some spray-on silicon compounds that can help. Remember to also check that the mainsail foot outhaul is slackened off.

BEARING AWAY

Don't forget this is a very effective and safe way of absorbing gusts while reaching in strong wind conditions, particularly under spinnaker. Rounding up tends to throw the mast to leeward (the wrong way), and can increase speed dramatically - all very exciting. However, bearing away throws mast to windward, speed falls off, and the motion feels much safer. This may sound odd, but try it sometime in lighter conditions to get confidence - it really works.

HEAVY HELM

The tiller should always be light and easy to handle, with just one hand. If not, then there is something wrong. Usual cause is the rudder blade has kicked back slightly. If this is not the problem then rudder may not be raked far enough forward. This can be changed by filling the pivot hole in the rudder blade and re-drilling slightly further forward (say 1/4").

RUDDER/DAGGERBOARD HUM

This is not an uncommon occurrence due to the difficulty in getting perfectly fair foils in a production environment, and even carefully hand made foils can develop a hum. This can be reduced or eliminated with a little fine tuning by filing or sanding the trailing edge of the foil concerned as follows:

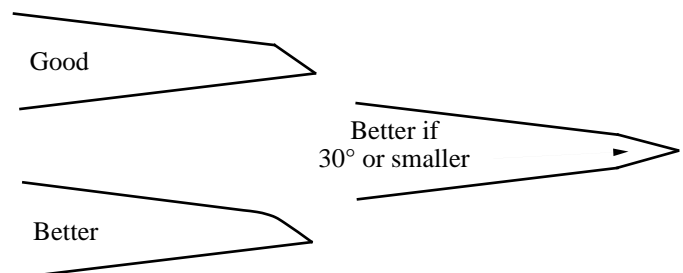

The bottom left shape is probably the easiest to achieve in practice, and the least likely to be damaged.

RUDDER VENTILATION

This can be a problem at very high speeds, and symptoms include a 'whoop' sound out the back, a huge rooster tail, and no steering. This normally only happens with speeds over 15 knots and fortunately the boat usually just keeps tracking straight.

The cause is air being sucked down the side of the rudder at high speeds, particularly if oversteering. Immediate cure is to waggle the rudder a little, or bring it back onto the

centerline until the water flow reattaches, or slow down.

To avoid, always keep the leading edge of your rudder smooth and fair, and if it becomes a consistent problem then the best cure is to fix a horizontal 'fence' to the leading edge of the rudder about 12 to 15" up from the bottom.

Fence

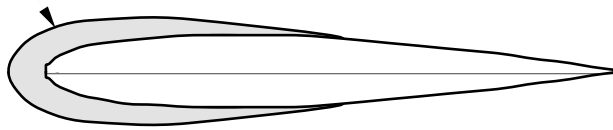

This will prevent the air from travelling down the blade and retains steering control, even if the top part of the rudder has ventilated. Such fences are fitted as standard on some higher performance models.

SHROUD TENSIONERS

When leaving the boat for any length of time with floats extended, the shroud tensioners on the F-31 should be let off. If not, the high tension could slowly bend the boat, due to 'creep' characteristics. This rule applies to all boats with adjustable backstays.

When initially setting up, shrouds with such tensioners must be adjusted to be just long enough to reach chainplate. There will then only be a small deflection when the tensioners are applied. Avoid the shrouds being too long as the resulting large deflection will put too much load on the tensioners, and this could put the mast at risk.

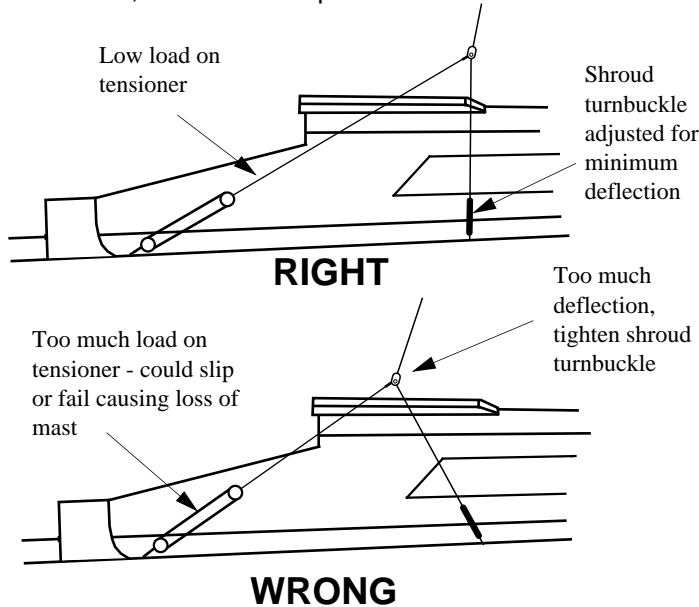

When sailing offshore, or for long periods, it is best and safest to fully tension the cap shrouds with the turnbuckles, so there is no reliance on the tensioners.

COMPRESSION PADS

These are fitted to the ends of F-24 and F-31 beams, to eliminate any gap or movement between the beam ends and the raised pads in the hull.

Do not remove, as this would cause the high compression loads in this area to be directed through the Upper Folding Struts, which, in the case of the F-24 and F-31 are not strong enough for such loads. They are designed for folding loads only, and the end mounting points may fail.

ion loads in this area to be directed through the Upper Folding Struts, which, in the case of the F-24 and F-31 are not strong enough for such loads. They are designed for folding loads only, and the end mounting points may fail.

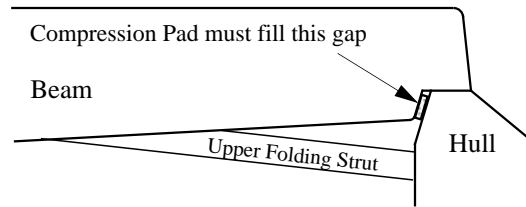

This would not cause a serious beam problem as the beams then simply move inboard to bear against the hull again. The boat is not threatened structurally. However, repairing an U.F.S. mounting point is difficult and expensive.

The plastic compression pads should be full width of the beam and bear evenly against both beam and hull, to avoid any point loading. This should be checked periodically.

The F-28 has similar pads on the forward beams, but these are not structurally important, their only purpose being to eliminate any movement for better rig stiffness.

WINGNETS

Take care that you do not step near the inner ends of the nets on the sides where lashing cannot be used in order to allow easy folding. Your foot may go through this gap. This area can be lashed if you wish, but should you forget to undo when folding, the eyelets in the nets will be pulled out.

BIMINI TOP STORAGE

A bimini top can be very useful, due to its ability to shade the cockpit. For storage, it can be hung over the stern and tied to the pushpit.

FLOAT/BEAM VENTS

The floats are vented through micro cowl vents fitted to the float transoms (or spring loaded vents just aft of the forward beams on earlier models). These are to prevent a build up of air pressure inside the floats on hot days, that could be enough to open up the hull to deck join.

The watertight bulkheads at the forward beam and Shroud chainplate bulkheads thus have very small holes near the top to allow venting throughout the float. Should the float ever be holed then these should be well above the flooded waterline, or at worst, only allow a very small amount of water through.

Should the float be inverted as in a capsized, then the airlock formed above these vents would prevent any significant flooding.

Hollow beams such as used on the F-28 also need draining/venting, and this is done through tubes extending from the bottom of the beams inside the floats. Should water appear from these then the source of the leak in the beams should be investigated, and repaired.

In the case of capsized, these tubes are designed to extend

above the floats flooded waterline, so as to prevent any water entering, and consequent loss of beam buoyancy.

RUST

Many grades of stainless steel will get an occasional brown stain in saltwater, that can look like rust. The grade used on most marine fittings is Type 304 or 303, and both of these will show this. Type 316, a more expensive grade, but actually slightly weaker, does not. All three grades can be used on a Corsair, depending on the application. To avoid this staining, always wash your boat down with fresh water after every outing. The brown stains will not appear if the salt is washed off.

CLEANING FLOATS

These can be extended for cleaning, if wished, while boat is on the trailer. Float supports must first be dropped down, and the boat then rocked one way. The 'high side' float can then be extended. Let the boat lean the other way and the remaining float can be extended. You will need to support the floats in some way once extended.

CLEAN BOAT HINT

If you are having problems with un-house trained birds on your boat, just leave a dummy, but lifelike, snake in the cockpit floor. Works well.

COLLISION

Any boat that has had a significant fore and aft collision on the float bow, or the folded beams have hit a low bridge, should always be thoroughly checked. No boat can be made collision proof, and hidden damage can result.

The complete float should always be checked after an impact, not just the bow area. A heavy fore and aft collision can actually propagate throughout the float, and has even generated cracks around the aft deck inspection hatch flanges for instance. In one case, a float hull had a vertical fracture in the aft beam area from a severe bow collision.

The beams should also be carefully checked if they have received any significant sharp impact. Being carbon fiber, they can be cracked or damaged from sharp impacts, and areas to check are around the lower folding strut brackets, and just inboard from the float. Even if no damage is found, continue to monitor for cracks over a period of time.

An area to check on early F-31s the deck to hull join flange on the main hull, just under the forward beams. This was a difficult join to do, and susceptible to cracking, particularly after a significant fore and aft collision. The diagonal wire braces as used on the F-31 tend to direct shock loads into the forward beam structure in this area. Any cracks in this flange should be investigated and repaired.

The forward beam bulkhead to hull join tape just adjacent to this flange area on the F-31 should also be investigated closely, as this is a known failure point from such collisions. Damage here may not be visible initially, but it may grow to eventually fail later, so continue to monitor. The boat still holds together should this tape delaminate, but obviously sailing should cease until it is repaired.

HURRICANE SURVIVAL

Hurricanes frequently cause damage to many boats, and on one occasion capsized a folded F-27. The owner had left it on a mooring, and being worried about possible damage from other boats breaking their moorings nearby felt it best to fold her up to reduce the 'target' profile. However this considerably reduces stability, and as stated earlier, this is limited while folded. As a result, no doubt while swinging sideways, the gale force winds blew the F-27 on its side.

The best procedure in such a situation is to get the boat out of the water, and trailer it inland away from harm - the perfect solution and used by most owners. If there is not time for this, then leave the floats extended, and pump water into each float and the main hull to weigh her down. Also remove the wing and bow nets. These don't have much windage, but it is surprising how much it can be in such winds. Lowering the mast will also reduce windage. Your boat is then as safe as anything can be in a hurricane.

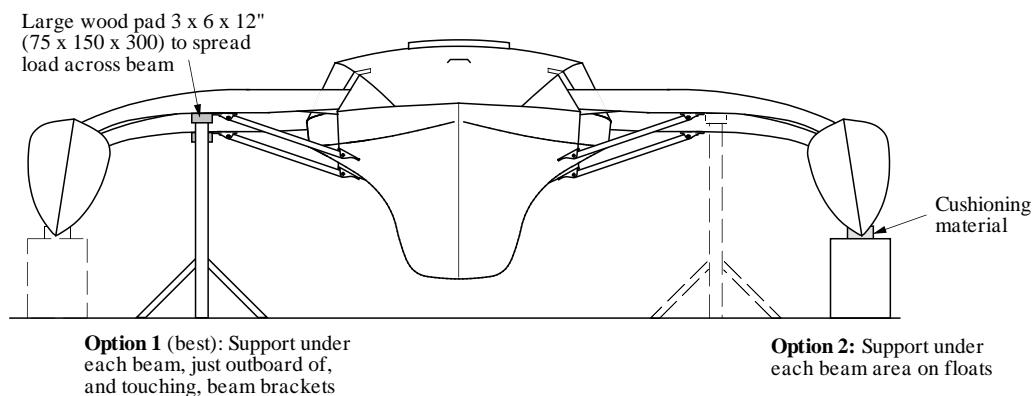

SUPPORT FOR MAINTENANCE

When necessary, the craft can be supported for short periods as detailed above for anti-fouling or other maintenance work.

SPECIFICATIONS

The following specifications may vary depending on options, and manufacturing or design changes

F-24 Mk II

L.O.A.....	24' 3"	(7.3m)
L.W.L.....	23' 7"	(7.2m)
Beam.....	17' 11"	(5.5m)
Folded Beam.....	8' 2"	(2.49m)
Draft Hull only	1'	(0.31m)
Draft D/board down	4' 5"	(1.36m)
Sail Area (Main and Jib)	365sq.ft.	(34sq.m)
Mast length.....	31' 10"	(9.7m)
Mast height above water.....	36' 2"	(11.05m)
Approx. Weight	1690lb	(770kg)
Load Capacity	1000lb	(450kg)
Opt. Watertank capacity.....	5 gals.	(20L.)
Opt. Holding tank capacity.....	N.A.	
Battery size	Group 24	deep cycle
Outboard recommended.....	4-8HP	
Height on trailer	8' 10"	(2.7m)
Approx. Towing Weight.....	2800lb	(1270kg)
Approx. wind capsize force	31 knots	
<i>(fully loaded with main & jib)</i>		

F-28

L.O.A.....	28' 5"	(8.66m)
L.W.L.....	26' 3"	(8.0m)
Beam	19' 9"	(6.1m)
Folded beam	8' 2 1/2"	(2.5m)
Draft Hull only	1' 2"	(0.36m)
Draft d/board down.....	4' 11"	(1.5m)
Sail Area (Main and Jib)	475sq. ft.	(44.2sq.m.)
Mast length.....	36' 10"	(11.22m)
Mast height above water.....	41' 4"	(12.59m)
Approx. Weight	2690lb	(1224kg)
Load Capacity	1350lb	(614kg)
Watertank capacity.....	16 gals.	(60L.)
Opt. Holding tank capacity.....	16 gals.	(60L.)
Battery size	Group 27	deep cycle
Outboard recommended.....	6-10HP	
Height on trailer	11' 6"	(3.5m)
Approx. Towing Weight.....	4100lb	(1865kg)
Approx. wind capsize force	34 knots	
<i>(fully loaded with main & jib)</i>		

F-28R

L.O.A.....	28' 5"	(8.66m)
L.W.L.....	26' 3"	(8.0m)
Beam	19' 9"	(6.1m)
Folded beam	8' 2 1/2"	(2.5m)
Draft Hull only	1' 2"	(0.36m)
Draft d/board down.....	4' 11"	(1.5m)
Sail Area (Main and Jib)	496sq. ft.	(46.1sq.m.)
Mast length.....	38' 4"	(11.22m)
Mast height above water.....	42' 10"	(12.59m)
Approx. Weight	2690lb	(1224kg)

F-28R continued

Load Capacity	1350lb	(614kg)
Watertank capacity.....	16 gals.	(60L.)
Opt. Holding tank capacity.....	16 gals.	(60L.)
Battery size	Group 27	deep cycle
Outboard recommended.....	6-10HP	
Height on trailer	11' 6"	(3.5m)
Approx. Towing Weight.....	4100lb	(1865kg)
Approx. wind capsize force	32 knots	
<i>(fully loaded with main & jib)</i>		

F-31

L.O.A.....	30' 10"	(9.4m)
L.W.L.....	30'	(9.15m)
Beam	22' 5"	(6.84m)
Folded beam	8' 2 1/2"	(2.5m)
Draft Hull only	1' 4"	(0.41m)
Draft d/board down.....	5' 6"	(1.67m)
Sail Area (Main and Jib)	599sq. ft.	(55.6sq.m.)
Mast length.....	40'	(12.2m)
Mast height above water.....	44' 11"	(13.7m)
Approx. Weight	3850lb	(1746kg)
Load Capacity	1600lb	(680kg)
Watertank capacity.....	16 gals.	(60L.)
Opt. Holding tank capacity.....	16 gals.	(60L.)
Battery size	Group 27	deep cycle
Outboard recommended.....	8-12HP	
Height on trailer	11' 6"	(3.5m)
Approx. Towing Weight.....	5300lb	(2410kg)
Approx. wind capsize force	36 knots	
<i>(fully loaded with main & jib)</i>		

F-31R

L.O.A.....	30' 10"	(9.4m)
L.W.L.....	30'	(9.15m)
Beam	22' 5"	(6.84m)
Folded beam	8' 2 1/2"	(2.5m)
Draft Hull only	1' 4"	(0.41m)
Draft d/board down.....	5' 6"	(1.67m)
Sail Area (Main and Jib)	647sq. ft.	(60sq.m.)
Mast length.....	42' 6"	(12.95m)
Mast height above water.....	47' 5"	(14.45m)
Approx. Weight	3150lb	(1430kg)
Load Capacity	2300lb	(680kg)
Watertank capacity.....	16 gals.	(60L.)
Opt. Holding tank capacity.....	16 gals.	(60L.)
Battery size	Group 27	deep cycle
Outboard recommended.....	8-12HP	
Height on trailer	11' 6"	(3.5m)
Approx. Towing Weight.....	4400lb	(2000kg)
Approx. wind capsize force	32 knots	
<i>(fully loaded with main & jib)</i>		

NOTES:

Mylar may be used for all sails
 (recommended).
 Sailcloth wgt. to suit wind in area sailed.
 All sails are to be fitted with telltales
 Max. roach is 41"/1040mm located 60%
 up leach
 Mainsail has 2 sets of reefpoints
 Mainsail to have Cunningham eye fitted
 Class emblem to be as shown.
 Jib to have 3 leach battens placed at
 equal distance on leach.
 Jib hanks to be for 1/4"/6mm wire

Sail	Luff	Leach	Foot	Area
Mainsail	29' 6" 9000	30' 6" 9300	11' 6" 3500	243sq.ft. 22.5sq.m.
Blade Jib	27' 8" 8445	24' 6" 7475	9' 9" 2960	122sq.ft. 11.3sq.m.
Asymmetric Spinnaker	33' 2" 10100	26' 11" 8200	20' 8" 6300	570sq.ft. 53sq.m.
Screacher	30' 10" 9400	24' 6" 7475	15' 5" LP 4700	243sq.ft. 22.5sq.m.



NOTES:

Square Top Mainsail as shown is required to be Class legal.

Roach to be no more than 26"/660mm, 64% up leach. (28"/710mm with F-28R).

Mainsail is designed to be almost flush with the top of the mast as shown -do not shorten luff, which has cutout as shown for halyard clearance.

Vertical Batten to be used at head to ensure head stands vertical.

Tack cutaway to be as shown

Mainsail has 2 sets of reefpoints,

Mainsail to have Cunningham eye fitted

Class emblem to be as shown.

Mainsail battens to be parallel with boom or slightly angled up as shown for easy roller furling.

Jib to have four leach battens placed at equal distance on leach.

Jib hanks to be for 9/32"/7mm wire

Sail	Luff	Leach	Foot	Area
Mainsail	33.8' 10300	35.1' 10700	12.0' 3660	300sq.ft 27.9sq.m.
Jib	30.1' 9175	26.9' 8200	12.4' 3780	175sq.ft 16.3sq.m.
Asymmetric Spinnaker	40.2' 12250	35.8 10910	27.6' 8410	780sq.ft 72.5sq.m.
Screacher	34' 10360	28.7' 8750	23.6' 7190	358sq.ft 33.3sq.m.
F-28R Mainsail	35.8' 10910	37' 11280	12.1 3690	321sq.ft 29.8sq.m.

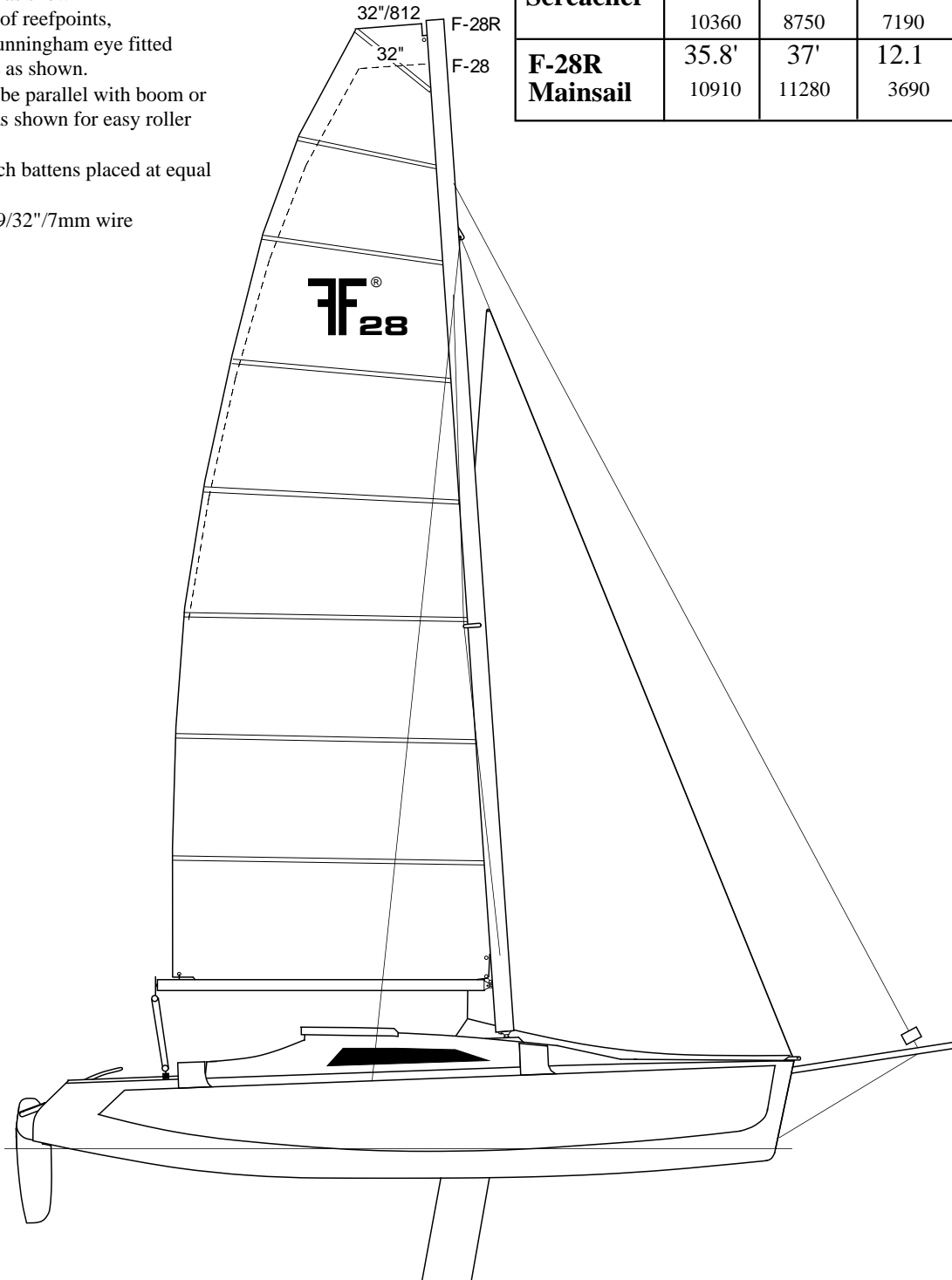

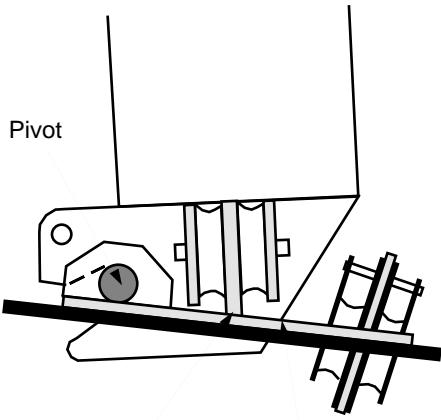

IMPORTANT
 If changing mast rake, make sure Center Web always bears **evenly on mast deck plate** here. Do not allow pivot pin to take full load of mast. Use aluminum packing on Deck plate if required.

Mast step should also touch against deck plate here

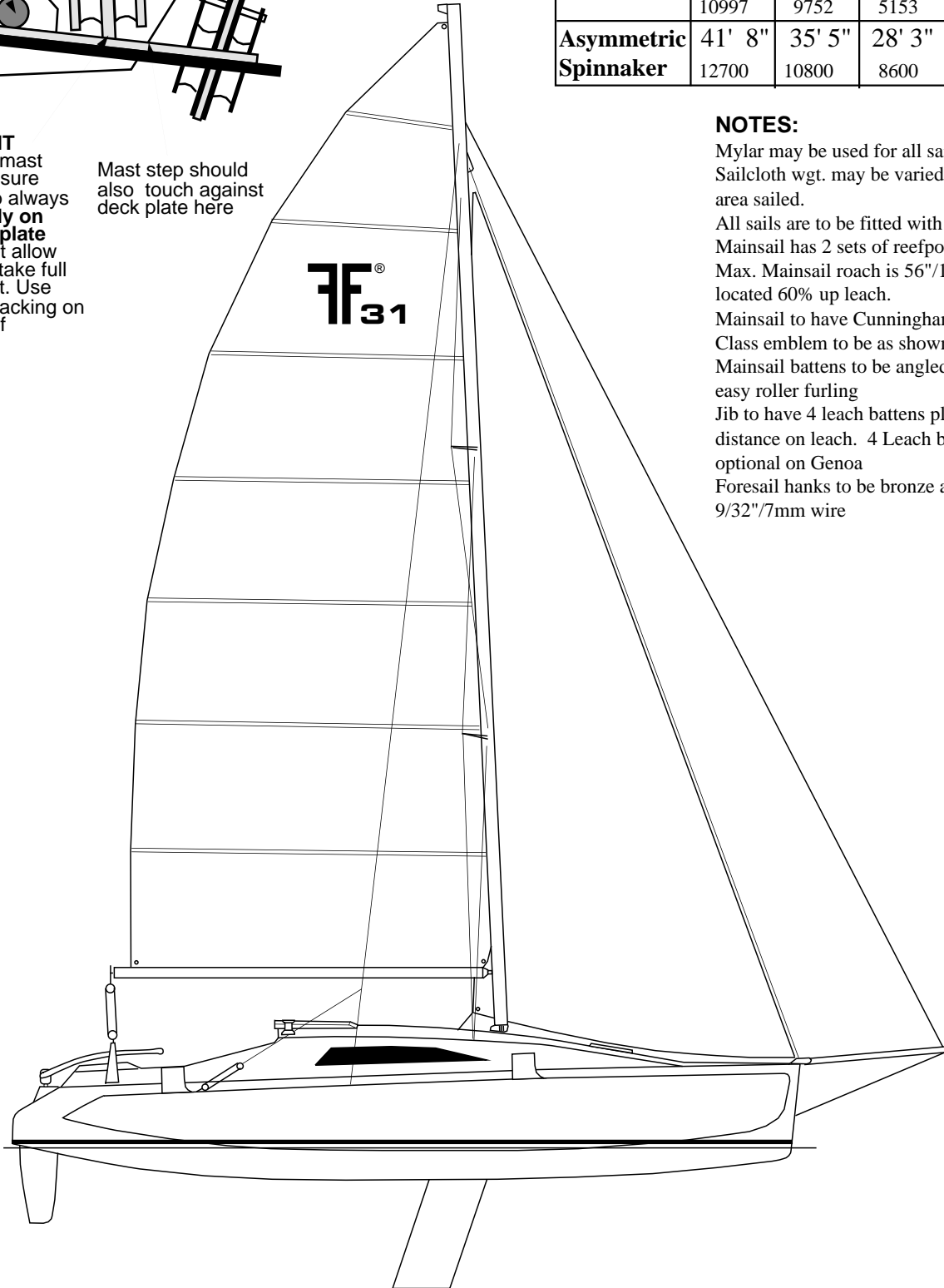

Sail	Luff	Leach	Foot	Area
Mainsail	37' 11275	39' 11880	14' 1" 4302	389sq.ft. 36sq. m.
Jib	36' 1" 10997	32' 1" 9775	12' 9" 3895	210sq.ft. 19.4sq.m.
Genoa	36' 1" 10997	32' 9752	16' 11" 5153	278sq.ft. 25.7sq.m.
Asymmetric Spinnaker	41' 8" 12700	35' 5" 10800	28' 3" 8600	1004sq. ft. 93sq.m.

NOTES:

- Mylar may be used for all sails.
- Sailcloth wgt. may be varied to suit wind in area sailed.
- All sails are to be fitted with telltales
- Mainsail has 2 sets of reefpoints
- Max. Mainsail roach is 56"/1425mm (located 60% up leach.
- Mainsail to have Cunningham eye fitted
- Class emblem to be as shown.
- Mainsail battens to be angled as shown for easy roller furling
- Jib to have 4 leach battens placed at equal distance on leach. 4 Leach battens are optional on Genoa
- Foresail hanks to be bronze and for 9/32"/7mm wire

F-31™ Sail Plan

F-31 is a trademark of Ian Farrier

NOTES:

Square Top Mainsail as shown is required to be Class legal.
 Roach to be no more than 34"/864mm, 60% up leach.

Mainsail is designed to be almost flush with the top of the mast as shown -do not shorten luff, which has cutout as shown for halyard clearance.

Vertical Batten to be used at head to ensure head stands vertical.

Tack cutaway to be as shown

Mainsail has 2 sets of reefpoints,

Mainsail to have Cunningham eye fitted

Class emblem to be as shown.

Mainsail battens to be parallel with boom or slightly angled up as shown for easy roller furling.

Jib to have four leach battens placed at equal distance on leach.

Jib hanks to be for 5/16"/8mm wire

Sail	Luff	Leach	Foot	Area
Mainsail	40.7' 12410	42.4' 12920	14.3' 4360	429sq.ft 39.7sq.m.
Jib	34.3' 10450	30.3' 9235	13.5' 4115	218sq.ft 20.2sq.m.
Asymmetric Spinnaker	45.2 13780	39.7' 12100	29.75' 9070	996sq.ft 92.2sq.m.
Screacher	39' 11890	34.8' 10610	25.8' 7865	449sq.ft 41.6sq.m.

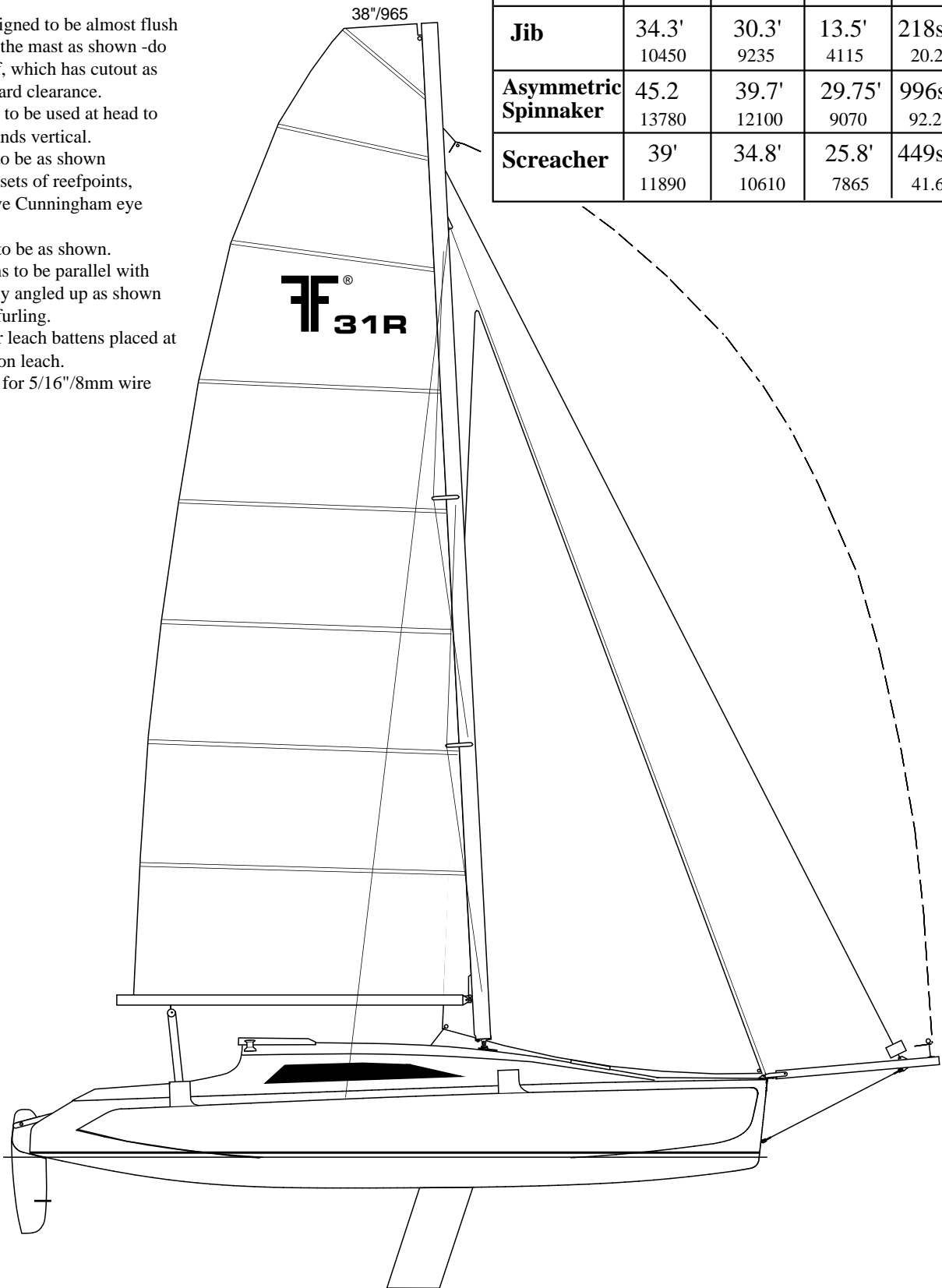

Options may be shown in these layouts, and specifications may be subject to change.

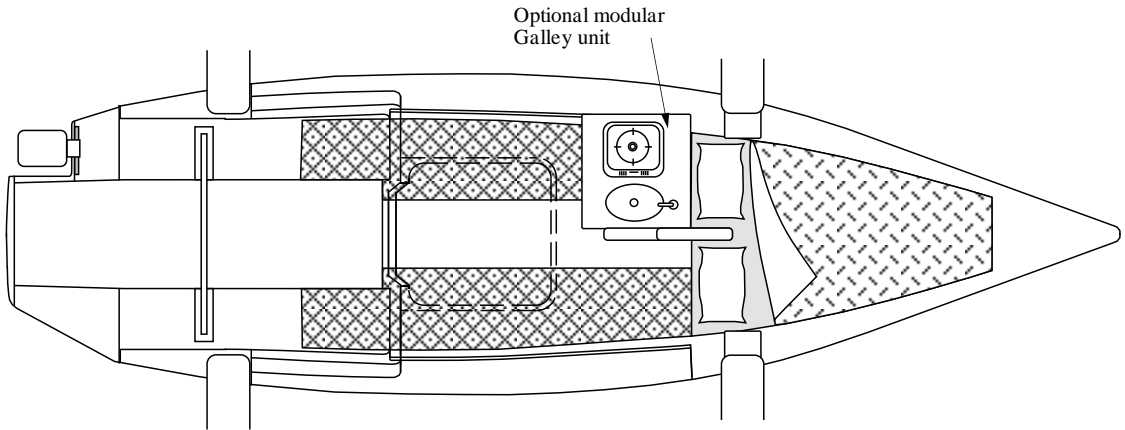

F-24 INTERIOR

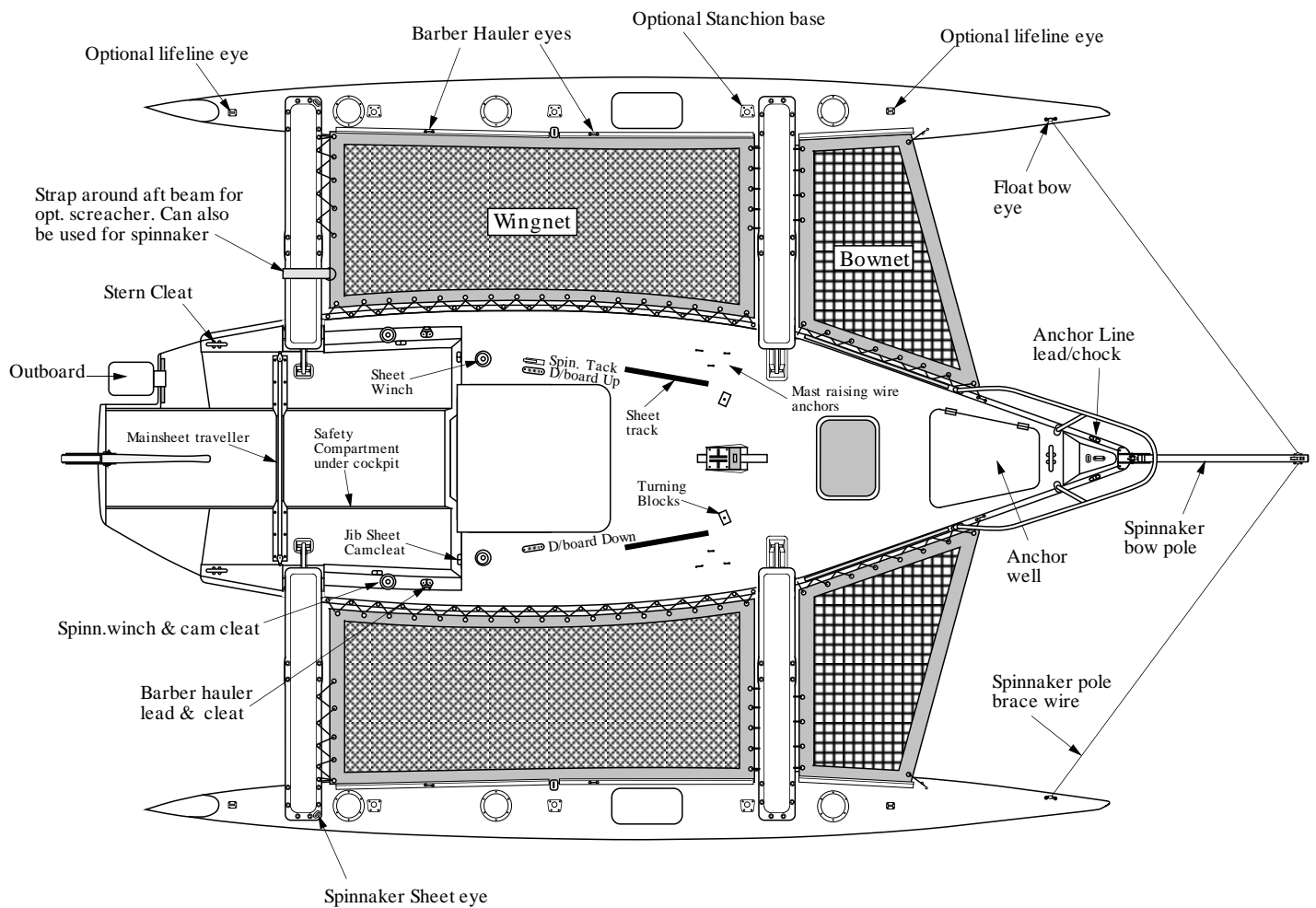

F-24 DECK LAYOUT

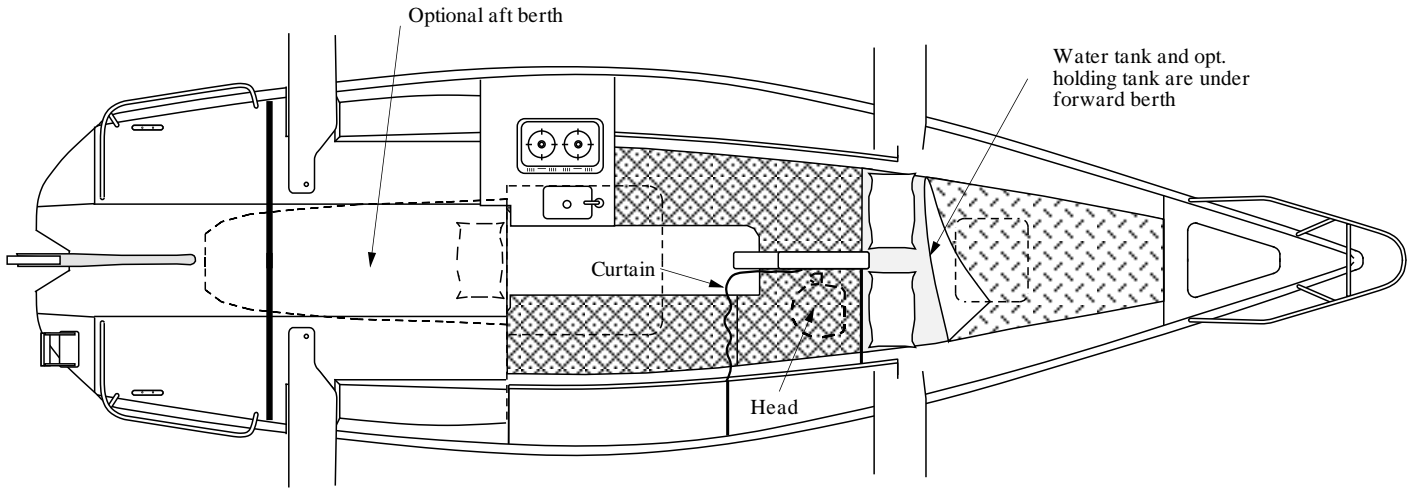

F-28 INTERIOR

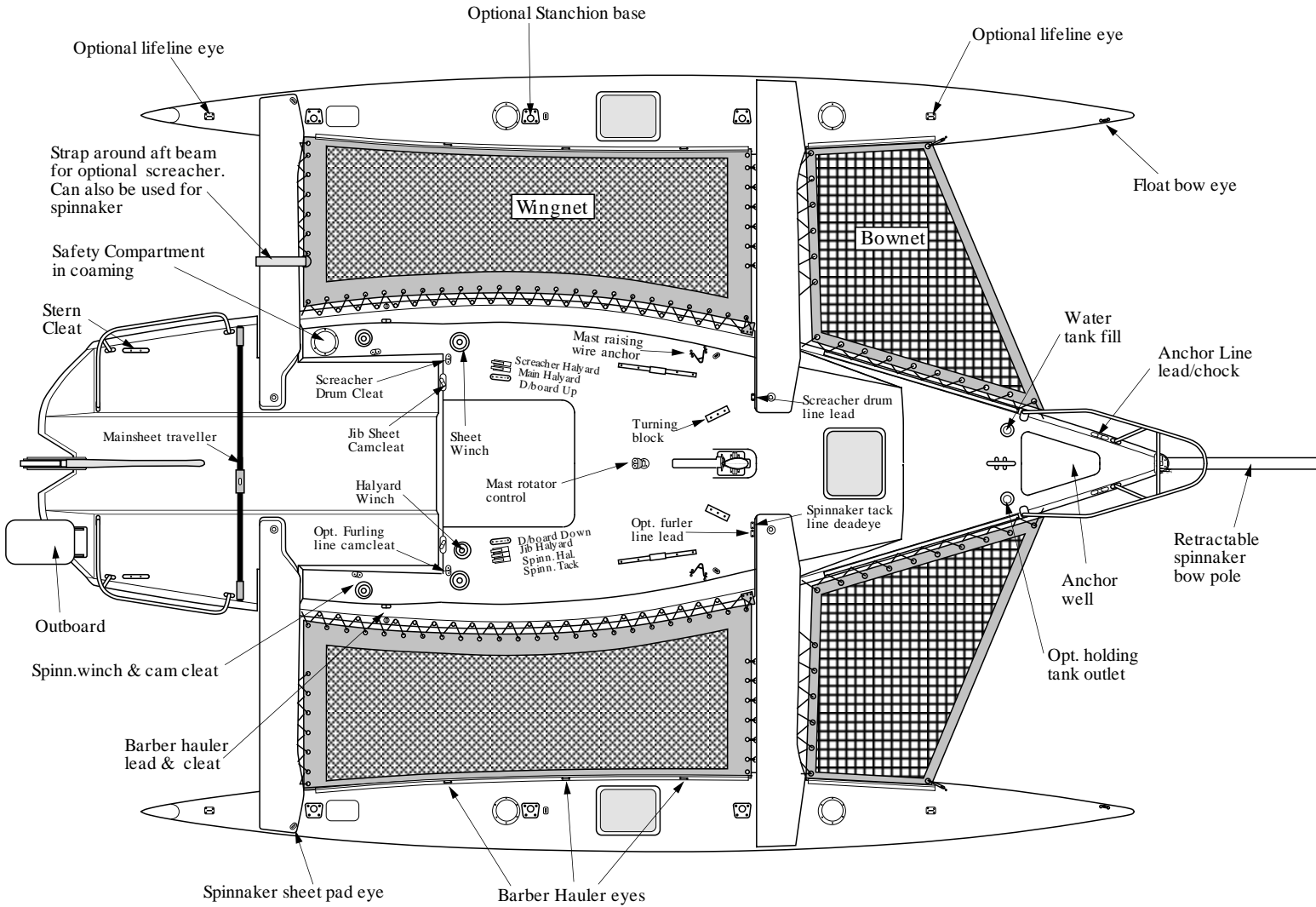

F-28 DECK LAYOUT

Options may be shown in these layouts, and specifications may be subject to change.

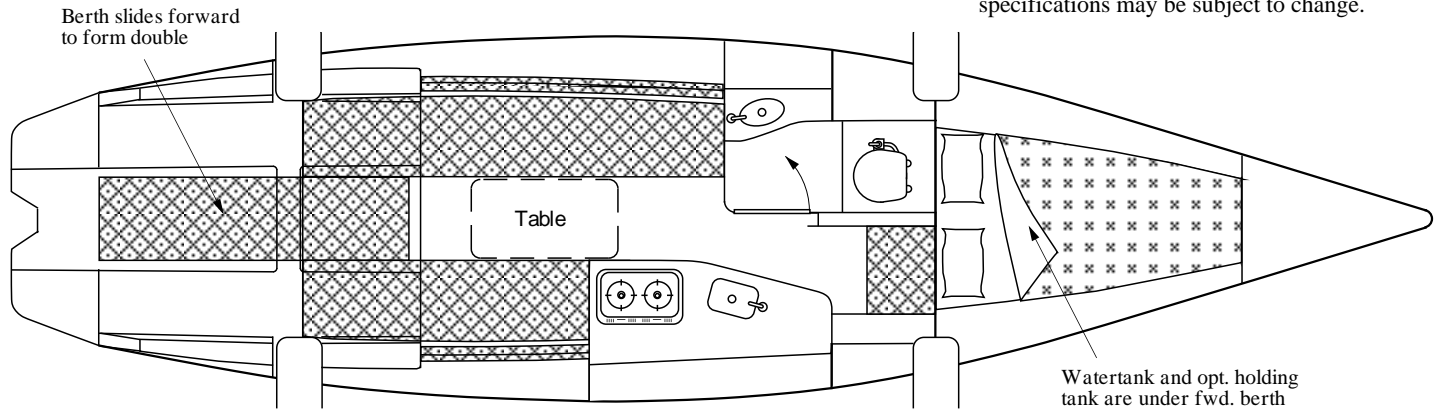

F-31 AFT COCKPIT INTERIOR

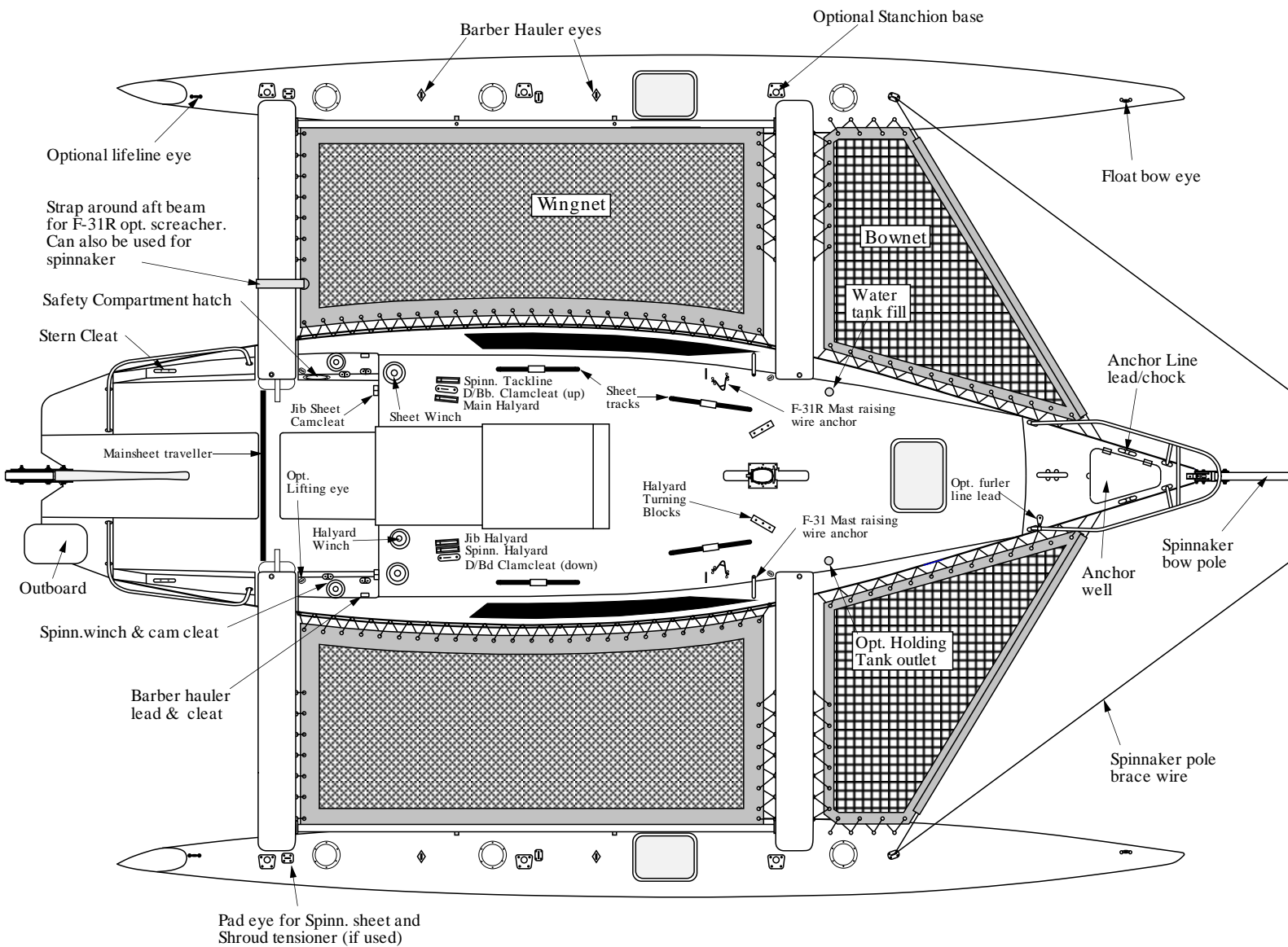

F-31 AFT COCKPIT DECK LAYOUT

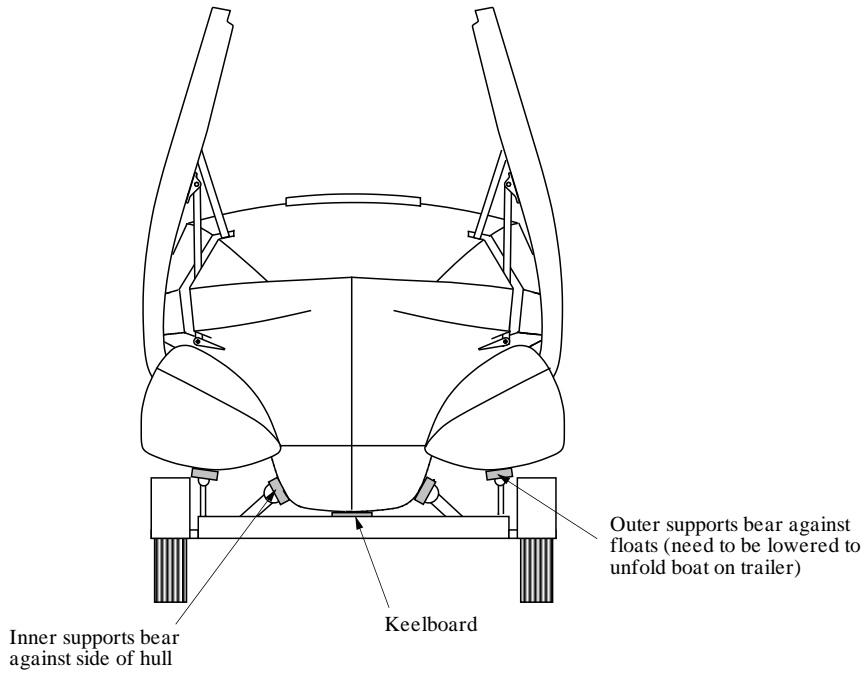

All supports should bear evenly and equally against boat

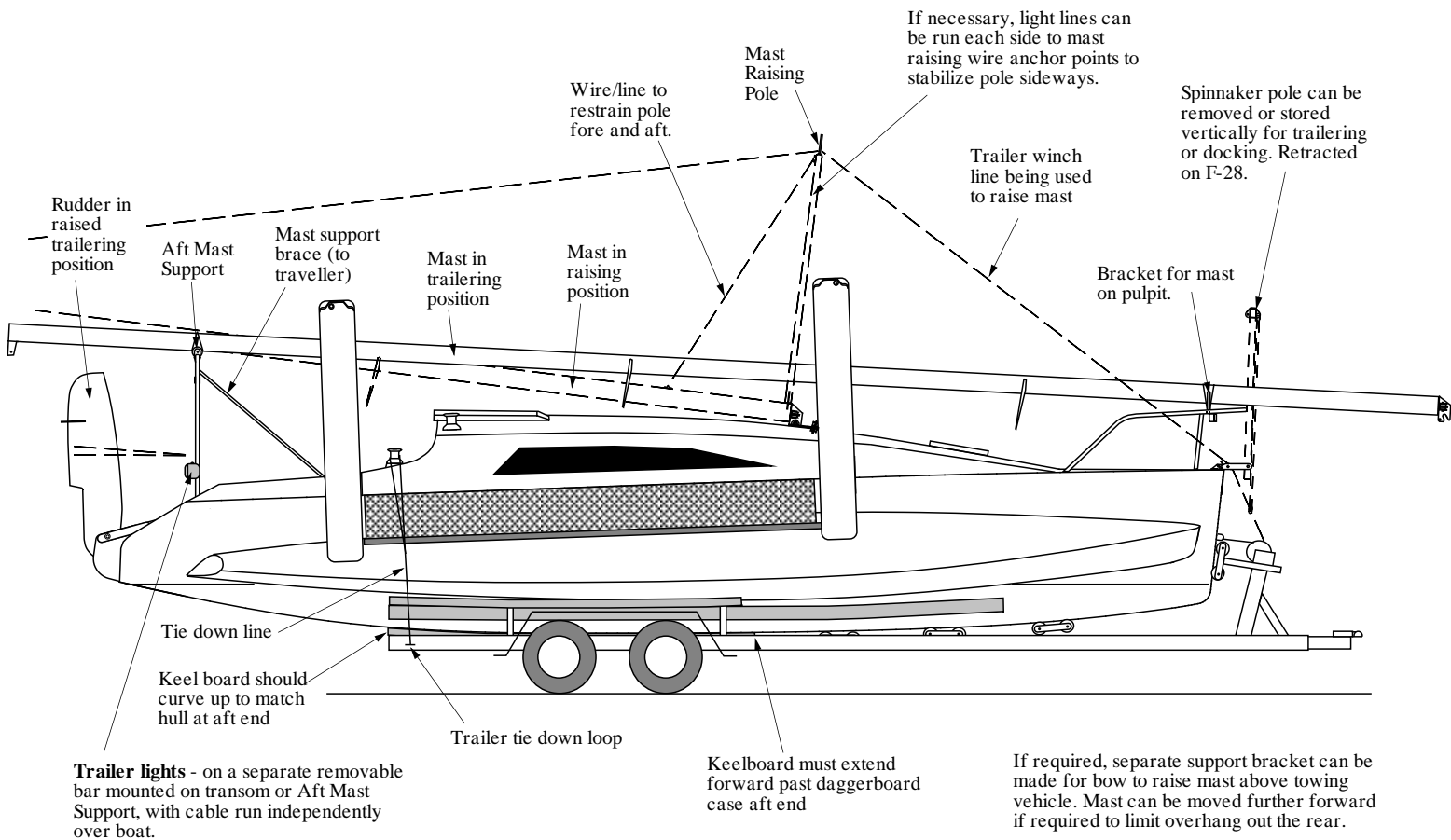

Always check that trailering setup complies with local regulations

TYPICAL TRAILER SETUP

(F-31 Aft Cockpit Version Shown)

WARRANTY AND LIMITATION OF LIABILITY

Seller warrants, for a period of one year from the date of delivery, to the original purchaser, that the F-24/F-27/F-28/F-31 will be free of defects in material and workmanship. Seller's sole obligation under this warranty shall be limited to replacing, correcting or repairing any part manufactured by Seller which is determined by Seller to be defective by reason of faulty workmanship or material. This warranty shall not apply to:

- a. Defects caused by accident, misuse, neglect, improper repair, lack of maintenance, normal wear and tear, negligent operation, or improper modification by persons other than Seller's employees.
- b. All parts or accessories not supplied by Seller and any part not manufactured by Seller. Any warranty on such parts, if possible, will be passed on to Purchaser, and Seller will agree to act as Purchaser's agent in any warranty claims on these parts.
- c. Any discoloration, crazing or cracking on all exterior finishes (including paint, gelcoat and anodizing). Only the best gelcoat and paints are used on the F-24/F-27/F-28/F-31 but they cannot be warranted as they may be affected by climate or other factors beyond the control of the Seller.
- d. Any damage caused by improperly rigging, trailering, or launching.
- e. Defects or faulty workmanship caused by persons other than the manufacturer, a currently authorized dealer, or a Corsair-approved repair facility, in modifying the F-24/F-27/F-28/F-31 or in adding, altering, or removing equipment to the F-24/F-27/F-28/F-31 whether or not such equipment was supplied by the manufacturer, or if such modifications, additions, or equipment removal by such persons have not been performed in strict accordance with accepted boat and yacht building practice and approved in writing by the manufacturer.
- f. Any vessel that has been used in a trans-oceanic passage exceeding two hundred (200) nautical miles from any coast.

Seller further warrants, for a period of five (5) years, that the hulls, beams, and folding system of the F-24/F-27/F-28/F-31 shall be free of any structural failure during normal operation. Seller's obligation under this warranty shall be limited to replacing, correcting or repairing any failed part which, in the judgment of the seller, has impaired the structural integrity of the F-24/F-27/F-28/F-31. This structural failure warranty shall

be void if Seller should determine that said components have been subjected to any abuse, including but not limited to collision with other vessels, structures or objects.

Seller further warrants, for a period of five (5) years, that the hull, deck, floats, beams, and other fiberglass parts manufactured by seller will be free of voids and blisters. Seller's obligation under this warranty shall be limited to repairing the void or blister. Seller reserves the right to exclude from this warranty provision those portions of any vessel subjected to prolonged or extended immersion unless previously protected by proper application of appropriate anti-foulant paint.

Purchaser shall be responsible for returning the F-24/F-27/F-28/F-31, or any defective part, to the Seller's plant, for any warranty repairs, with all transportation charges paid by the Purchaser. Seller, may at its option, direct Purchaser to transport the F-24/F-27/F-28/F-31 to an independent repair facility for any needed replacements, corrections, or repairs.

Purchaser agrees to promptly notify Seller of any condition or part which Purchaser believes to be defective within thirty (30) days of discovering defect.

Purchaser and Seller agree that THE FOREGOING WARRANTY IS EXPRESSLY IN LIEU OF ANY AND ALL OTHER REPRESENTATIONS, WARRANTIES OR CONDITIONS EXPRESSED OR IMPLIED, INCLUDING ANY IMPLIED WARRANTIES OR CONDITIONS OF MERCHANTABILITY OR FITNESS FOR A PARTICULAR PURPOSE, AND IS IN LIEU OF ANY OBLIGATIONS OR LIABILITIES OF SELLER TO PURCHASER, WHETHER FOR LOSS OF USE OF THE F-24/F-27/F-28/F-31, LOSS OF TIME, INCONVENIENCE, COMMERCIAL LOSS, OR FOR DIRECT, SPECIAL OR CONSEQUENTIAL DAMAGES OR OTHERWISE ARISING OUT OF THE USE OF THE F-24/F-27/F-28/F-31. THE PURCHASER SPECIFICALLY ACKNOWLEDGES AND AGREES THAT THE FOREGOING SHALL SURVIVE ANY FUNDAMENTAL BREACH OF THIS AGREEMENT. IN SOME JURISDICTIONS, THE MANUFACTURER IS PROHIBITED FROM EXCLUDING OR LIMITING IMPLIED WARRANTIES. IN THOSE JURISDICTIONS THE MANUFACTURER EXPRESSLY LIMITS ANY IMPLIED WARRANTIES TO THE GREATEST EXTENT AND TO THE SHORTEST DURATION ALLOWED BY LAW.

MAINTENANCE & SAFETY CHECKLIST

For continued safe and enjoyable operation, it is essential that regular maintenance be carried out. Trimarans are actually more like aircraft in many aspects, and it is important to conduct regular maintenance and safety checks to locate any potential problems before they become serious.

The following Maintenance Safety Checksheet has thus been developed and it is strongly recommended that a full check be undertaken every 6 months.

In general, after every sail, the complete boat and trailer should always be thoroughly washed down with fresh water. This is very important to keep that new look, and to prevent rust taking hold on the trailer. Particularly wash out the brakes and suspension area of the trailer. Regularly check the bilges of the center hull and the floats for any water.

Sails should always be rolled up or folded (the same way as you receive them) - dried first if wet.

If possible, keep your boat under cover, as this will ensure the finish keeps its gloss for the life of the boat. Even the best gelcoat finish will eventually begin to fade.

MAST

Masthead sheaves should turn freely, and clevis or pivot pins should not be worn or show signs of distortion.

Spinnaker halyard and Jib halyard sheaves should turn freely, and clevis or pivot pins should not be worn or show signs of distortion.

Forestay tab/nose should be checked for any cracks or signs of distortion

All other stay attachments to mast should be checked for distortion or corrosion.

Mast step should be checked for any distortion or cracks

Mast step sheaves should turn freely, and clevis or pivot pins should not be worn or show signs of distortion.

Boom gooseneck pins should be checked for any signs of wear or distortion

RUNNING RIGGING

All halyards should be checked for broken

strands or wear, particularly where they enter the mast when sails are up, and where rope clutches engage. A sleeve over rope tail at rope clutch area can prolong life and give better clutch holding power

Spinnaker halyard should have any worn area at the top cut out and the halyard retied or spliced to the snap shackle.

STANDING RIGGING

All stays should be checked for broken strands or corrosion, particularly at end swages. If any stays are badly kinked, replacement should be considered.

Stainless steel is prone to fatigue, and in a trailer boat it is not uncommon to get kinks in the stays while rigging or derringing. This further fatigues the wire, and even though the stays are oversize, it is strongly recommended that all stays be replaced after 3 to 5 years.

Check all turnbuckles for corrosion, and that all locking rings or pins are in place, and work correctly.

HULLS

Check bow U-bolt and spinnaker eye for any movement.

Check all chainplates for any signs of movement

Check deck to hull joins where visible for any delamination or cracking in join.

Check wing nets, particularly eyelets for wear.

Wingnets should be replaced every three or four years. The taped edges are usually the first to fail, and sometimes just redoing these will extend the net life. If replacing nets, avoid any close weave fabrics as these can trap wind underneath, creating unwanted lift. Bow nets, in particular, should always be of a very open weave.

Check rudder case for any sign of stress cracks, or corrosion, particularly at lower end. Rudder blade should swing up and down easily in case, but without any slop.

Check rudder blade or shaft around bottom edge of rudder case for any stress cracks. Replace if necessary

- Check leading and trailing edges of rudder blade for any delamination or splitting.
- Check rudder control lines for wear, and replace pull down line every year
- Check daggerboard around bottom edge of hull for any stress cracks
- Check leading and trailing edges of daggerboard for any delamination
- Check control lines for wear and replace if necessary
- Check traveller welds for any signs of cracking
- Check Hull area around Lower Folding Strut brackets for any signs of damage/cracking
- On early model F-31s check around main hull/deck join flange just under forward beams for any cracking in join.
- Check all deck fittings for any cracks or wear.

BEAMS

- Check all beam join flanges for any signs of delamination or cracking.

WARNING

Any delamination or cracking in beam flanges should be regarded as serious and must be repaired without delay. Otherwise a small crack can grow until it can cause failure.

- Check top non-skidded surface of beams for any movement or 'softness' under foot, or if 'oil canning' or rippling of the top beam surface can be observed while sailing. Must be inspected and repaired immediately as this could be a serious fault.
- Check that plastic compression pads remain on inner ends of beams and that they bear against deck/hull when floats are extended. Also check around this area for any signs of damage or cracking, on both deck/hull and beam.
- Lightly grease beam bolt threads with a teflon grease

FOLDING SYSTEM

- Check all pivot pins for corrosion, and that circlips or nuts are properly fitted.
- Check hull and beam brackets for any looseness or cracking
- Check all folding struts have plastic bushes at pivot points, and that there are no major cracks in welds (these welds are not structurally important, and small cracks are not significant - these resulting from flex during folding)
- Check locking pins (for when floats are retracted) and brackets for excessive wear. Rubber stop should be replaced if worn excessively.
- Check that floats do not bear directly on to the main hull. There should be a bumper on the hull side, or a minimum 1/8" gap.

TRAILER

- Check Trailer winch line for wear

CAUTION

When raising the mast by using the winch there is considerable tension on the jib halyard and winch line. Be doubly careful when checking these for wear as failure of either one could result in severe injury.

- Check all trailer supports bear evenly against hulls
- Trailer should be regularly cleaned and oiled
- Check wheel bearings for wear
- Check operation of brakes.

Any defects or problems found during this check should be remedied immediately.

This Checklist is intended as a guide only and may not cover every potential problem. Owner should always check every aspect of boat on a regular basis.

Corsair Marine, Inc., 150 Reed Ct., Chula Vista, CA 91911, U.S.A.
www.corsairmarine.com